**Laser Engraving/Cutting Machine
Manual**

Model	120000	120000
Material	Blue and grey	Blue and grey
Power supply	110V/200V	110V/200V
Weight	25kg	25kg
Dimensions	1200x1200x1200	1200x1200x1200
Capacity	1000	1000
Lead type	1000	1000
Power supply	110V/200V	110V/200V
Maximum speed	1000	1000
Maximum weight	1000	1000
Software	1000	1000
Printing	1000	1000
Workbench adjustment	1000	1000
Printing resolution	1000	1000
Resolution	1000	1000
Power supply	110V/200V	110V/200V
Weight	25kg	25kg
Dimensions	1200x1200x1200	1200x1200x1200
Capacity	1000	1000
Lead type	1000	1000
Power supply	110V/200V	110V/200V
Maximum speed	1000	1000
Maximum weight	1000	1000
Software	1000	1000
Printing	1000	1000
Workbench adjustment	1000	1000
Printing resolution	1000	1000
Resolution	1000	1000

User Instructions

Laser Engraver



Technical Data/ Device Specification Mechanics

Model		
Basic info	USB690	USB690
Color	Blue and gray	Blue and gray
Processing/ cutting area	600 x 900mm	600 x 900mm
Workbench	Honeycomb & aluminum knife	Honeycomb & aluminum knife
Laser capacity	80W	100W
Laser type	CO2 sealed laser tube	CO2 sealed laser tube
Power supply	110V/ 60Hz	110V/ 60Hz
Minimum shaped text	2mm*2mm	2mm*2mm
Maximum shaped text	1mm*1mm	1mm*1mm
Fan	Built-in	Built-in
Software	RDWORKS V8	RDWORKS V8
Display	LCD Digital	LCD Digital
Workbench adjustment	Electric adjustment	Electric adjustment
Cutting thickness	0-15mm (varies according to materials and power capacity)	0-15mm (varies according to materials and power capacity)
Resolution ratio	≤4500dpi	≤4500dpi
Supported software	Coreldraw /Autocad/ Engrave Lab/ Illustrator output	Coreldraw /Autocad/ Engrave Lab/ Illustrator output
Dichroic cutting	256 colors	256 colors
Assisted positioning	Red light positioning	Red light positioning
Protection	Air-blowing flame retardant/ Water protection	Air-blowing flame retardant/ Water protection
System environment	Windows xp/win 7/win 8/win 10	Windows xp/win 7/win 8/win 10
Graphic format supported	All formats that can be recognized by coreldraw and autocad, such as JPG, BMP, AI, PLT, etc.	All formats that can be recognized by coreldraw and autocad, such as JPG, BMP, AI, PLT, etc.
Data transmission	USB 2.0/ Network port/ U-disk	USB 2.0/ Network port/ U-disk
Optional configuration	Regular rotation axis (not included)	Regular rotation axis (not included)
Dimensions	144×106×96 cm	144×106×96 cm
Net weight	180kg	180kg
Package dimensions	156×119×118 cm	186×119×118 cm
Gross weight	247kg	257kg

CONTENTS

Chapter 1 General.....	5
1.1 General Information.....	5
1.2 Designated.....	6
1.3 Disposal Remarks.....	7
1.4 Device Specification.....	8
Chapter 2 Safety.....	8
2.1 General Safety Information.....	8
2.2 Laser Safety Information	9
2.3 Safety Precautions when Operating the Device.....	10
2.4 Warning and Information Labels.....	10
Chapter 3 Process of Installing.....	11
3.1 Unpacking.....	11
3.2 Contents of Delivery.....	11
3.3 Location.....	13
3.4 Before Installation.....	13
3.5 Exhaust System – Requirements.....	14
3.6 Built-in Air Pump.....	15
3.7 Computer – Requirements.....	15
3.8 Connections.....	15
3.8.1 Connecting the Mains.....	15
3.8.2 Connecting the Computer.....	16
3.8.3 Connecting the Exhaust System.....	17
3.8.4 Connecting the Cooling System.....	17
3.8.5 Safety Grounding.....	18
Chapter 4 Operation.....	19
4.1 Machine View.....	19
4.2 On/ Off Switch.....	23
4.3 How to adjust focus distance.....	23
4.4 How to use the control panel.....	24
4.4.1 Control Panel.....	24
4.4.2 Function of the Buttons.....	25
4.4.3 The Main Interface.....	26
4.4.4 Menu Button.....	27
4.4.5 Speed.....	27
4.4.6 Max/ Min Power.....	27
4.4.7 File.....	28
4.4.8 U-disk File.....	29

4.4.9 Layer Parameter Setting.....	30
4.4.10 FN Button Menu.....	30
4.4.11 Z Move.....	31
4.4.12 Keyboard Lock.....	31
4.4.13 Manual Set+.....	31
4.4.14 Laser Set+.....	32
4.4.15 Origin Set.....	32
4.4.16 Factory Parameter Setting.....	33
4.4.17 Def. Fact Parameters.....	34
4.4.18 Auto Focus.....	34
4.4.19 Language.....	34
4.4.20 IP Setup.....	34
4.4.21 Diagnoses.....	35
4.4.22 Screen Origin.....	35
4.4.23 Axis Reset.....	36
4.4.24 Alarm Information.....	36
4.5 The First Time Running the Laser.....	37
4.6 Rotary Axis Attachment.....	38
4.7 For Laser Engraving.....	40
Chapter 5 Maintenance.....	43
5.1 Cleaning the Laser Machine.....	43
5.2 Cleaning the Optical Parts.....	43
5.2.1 Cleaning the Focus Lens.....	44
5.2.2 Clean the Mirrors.....	45
5.3 Maintenance the X/Y Rails.....	47
5.4 Check the Beam Path.....	47
5.5 Change Cooling Water for the Water Chiller.....	48
5.6 Maintenance Plan.....	48
5.7 Maintenance Plan.....	48
5.8 Cover Protection.....	49
5.9 Digital Display Power Supply.....	49
5.9.1 Images.....	49
5.9.2 Function.....	50
5.9.3 Advantages.....	50
5.9.4 Connection of Laser Power Supply.....	51
Troubleshooting.....	52

Chapter 1 General

1.1 General Information

Caution

Please read and follow this Operation Manual carefully before installation and operation. Damage to persons and/or material can result from not following individual points of the Operation Manual. Operation of the system is only permitted with equipment and spare parts supplied or listed in the spare parts and consumables lists.

Accessory equipment must be adjusted to the base machine. (Any queries, please contact the dealer or manufacturer.)

The following symbols are used for easier understanding of the Operation Manual:



If the Operation Manual is not observed, this symbol represents a particular danger for the operating personnel or the personnel responsible for maintenance.



This component is under voltage. In this area, strictly observe the safety instructions.

Introduction

This manual has been designated as the system, laser cutting machine installation and a user guide. The manual is divided into five chapters, including general information instructions, safety instructions, key components of every laser cutting system and the installation steps, operation instructions and maintenance instructions from LASER Company.

First, it should be emphasized that installation of each system must meet the requirements and be consistent with the installation requirements of LASER. If not, the machine will not work properly: poor performance, life shortened, increased maintenance costs and even machine damage.

The note provides a specific requirement of system installation, and we hope every customer try to understand these notes before installation and usage so that they can install and use it properly. If you have any installation problems, please feel free to contact our technicians and customer service team.

Chapter 1 General

1.1 General Information

Caution

Please read and follow this Operation Manual carefully before installation and operation. Damage to persons and/or material can result from not following individual points of the Operation Manual!

Operation of the system is only permitted with equipment and spare parts supplied or listed in the spare parts and consumables lists.

Auxiliary equipment must be adjusted to the base machine. (Any queries, please consult the dealer or manufacturer.)

The following symbols are used for easier understanding of the Operation Manual.



If the Operation Manual is not observed, this area represents a particular danger for the operating personnel or the personnel responsible for maintenance.



Caution: This component is under voltage. In these areas, strictly observe the safety instructions regarding electricity. Care is to be taken in particular during maintenance and repair work.



Caution: In this area, pay attention to the possible dangers of the laser beam.

Tips:

Notes or information on individual components of the device simplify the use or make it more understandable.

Attention

1. Read the manual carefully before operating. The following safety measures must be strictly enforced and abided by. Never operate laser machinery unless you have been properly trained.
2. Make sure to run the water pump before you switch on the laser.
3. Never leave the laser unattended. Remain with the machine when it is running at all times so that you can hear and observe abnormalities and potential hazards.
4. Never under any circumstances attempt to dismantle your machine as laser and high voltage parts can cause severe injury.
5. Always connect the ground connector to a grounded outlet to help eliminate static electricity.
6. Top lid should remain closed when the machine working.
7. Keep unit in areas that are clean and dry with good air quality, as certain pollutants can cause electrical interference with the device.

8. Caution: Do not open machine while in operation or while engraving reflective materials. Doing so will cause the laser to deviate or reflect which can result in blindness or serious injury requiring medical attention.
9. In rare cases of fire, please locate the nearest fire extinguisher, hose, or call your local fire department.
10. Coolant temperature should be kept between 60-85F. Store coolant at a consistent temperature as fluctuations can cause the tube to break if too cold and explode if overheated. For best results use deionized water. If deionized water can't be used, distilled water is an acceptable substitute. Always keep your coolant clean and clear for proper functioning of your unit.
11. Requires a 110 v 60Hz power supply. Do not run laser through an unstable or incompatible power source under any circumstances.
12. Warning: Never operate laser near flammable materials. The laser beam is invisible and poses an extreme fire risk to operators.
13. DO NOT run machine continuously for more than 8 hours. To keep your laser tube working optimally, stop your machine for a half hour every 7 hours.
14. Maximum current for laser tube is 20mA
15. Currents above 20mA will result in puncturing of the tube and damaging of the laser.
16. CE iSO9001 FDA

Manufacturer shall not be held responsible for damages or injury resulting from improper use or not following the safety measures.

1.2 Designated

The machine is used for engraving and cutting signs, stamps and suchlike.

A wide variety of materials such as rubber, acrylic, coated metal, tin, special steel, anodized aluminum, cork, cardboard, glass, leather, marble, several plastics and wood can be processed on the laser.

1. The engraving process must be performed with a perfectly adjusted machine.
 2. It is absolutely necessary of using air system when process all the materials.
 3. Use of the system in other areas is against the designated use. The manufacturer does not admit liability for damage to personal and/or equipment resulting from such use.
 4. The system must be operated, maintained and repaired, by personnel that are familiar with the designated field of use and the dangers of the machine!
 5. Non-observance of the instructions for operation, maintenance and repair described in this Operation Manual excludes any liability of the manufacturer if a defect occurs.
 6. Please be cautious when processing conductive materials (carbon fibers). Conductive dust or particles in the ambient air might damage electrical components and lead to short circuits.
- Bear in mind that those defects are not warranted.

1.3 Disposal Remarks

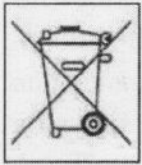

Do not dispose the machine
with domestic waste!

Electronic devices have to be disposed according to the regional directives on electronic and electric waste disposal. In case of further questions, please ask your supplier. He might take care of proper disposal.

Standard

Red Dot Pointer, Pass-through Door, Air Assist, Water Pump, Exhaust Fan, Honey Comb Table, 1.5" (38.1mm) Focus Lens, LCD Display, 3D Engraving, Water Protection, Emergency Stop Open Cover Protection, Motorized Table

Optional:

Rotary Attachment, Auto-focus Worktable, Water Chiller Attachment, High Resolution Head (up to 1000DPI while standard laser head Max is 500DPI), Air Compressor, Water Filter

Control System

Laser power adjustable from 0 -100% (typically 10-100%)

Interface hardware USB: connect to PC and U-disk

Ethernet: connect to PC

Interface Software RDWorksV8

Operating Modes Optimized Raster, Vector, and Combined Mode

Buffer Memory 128MB Standard

Cooling System

Water Cooling System

Water Cooled

Electricity, Power, Fuse

Electricity requirement 110 or (220V~ 240)volts, 50 or 60 Hz, single phase

Power consumption 1200W

Recommended fuse 15A (220V), 15A (110V)

Ambient Conditions

Ambient temperature +5°C to +25°C / 59°F to 77°F

Humidity 40% to max.70%, not condensing

Laser Safety

Laser class CDRH Laser Safety

Laser Class 4(H)

CE compliant, FDA approved

1.4 Device Specification

The manufacturer's label is located on the device (see Figure below).



It is recommended to enter data such as serial number and year of manufacture into the manufacturer's label below so that you always have this data handy if you have problems with your device or require spare parts.

Chapter 2 Safety

2.1 General Safety Information

All personnel involved in installation, set-up, operation maintenance and repair of the machine must have read and understood the Operation Manual and in particular the "Safety" section.

It is recommended that the user should generate company-internal instructions considering the professional qualifications of the personnel employed in each case, and the receipt of the instruction/Operation Manual or the participation at introduction/training should be acknowledged in writing in each case.

Safety Conscious of Working

The machine must be operated by trained and authorized personnel.

The scopes of competence for the different activities in the scope of operating the machine must be clearly defined and observed, so that under the aspect of safety, no unclear questions of competence occur. This applies in particular to activities on the electric equipment, which must be performed by special experts.

For all activities concerning installation, set-up, start-up, operation, modifications of conditions and methods of operation, maintenance, inspection and repair, the switch-off procedures that may be provided in the Operation Manual must be observed.

Safety Information for the User and/ or Operating Personnel

1. No working methods are permitted that affect the safety of the machine.
2. The operator must also ensure that no unauthorized person works with the machine (e.g. activating equipment without authorization).
3. It is the duty of the operator to check the machine before working for externally visible damage and defects, and to immediately report changes that appear (including behavior during operation) and affect the safety.
4. The user must provide that the machine is only operated in perfect condition.
5. The user must guarantee the cleanness and accessibility at and around the machine by following corresponding instructions and controls.
6. Principally, no safety components can be removed or disabled (already here we emphasize the imminent dangers, for example severe burns and loss of eye-sight. If the removal of safety components is required during repair and service, the replacement of the safety components must be performed immediately after completion of the service and repair activities.
7. Preparation, retooling, change of work piece, maintenance and repair activities must be performed by trained personnel when the equipment is switched off.
8. It is forbidden to perform unauthorized modifications and changes to the machine. It is emphasized that any unauthorized modifications to the machine are not permitted for safety reasons.

2.2 Laser Safety Information



1. To assess the potential dangers laser systems pose, they are classified into 4 safety classes. It is a device of class 4. This is guaranteed by the protective housing and the safety installations.

Please note that improper operation of the device can override the status of safety class 4 and can cause the emission of harmful radiation.

2. This laser engraving system contains a carbon dioxide (CO₂) laser of class 4 that emits intensive and invisible laser radiation. Without safety precautions, the direct radiation or even diffuse reflected radiation is dangerous!
3. Without safety precautions, the following risks exist with exposure to laser radiation:
Eyes: Burns to the cornea
Skin: Burns
Clothing: Danger of fire
4. Never try to modify or disassemble the laser and do not try to start up a system that had been modified or disassembled!
5. Dangerous radiation exposure can result from the use of operation or adjustment equipment other than that described here, and if different operational methods are performed.

2.3 Safety Precautions when Operating the Device

The machine must be operated by trained and authorized personnel.

In the operation, when there is no water, less water or dirty water, the laser machine will be off, so you should check the water situation. For example, whether there is enough water, and whether the water is clean.

We suggest you choose purified water or distilled water.

Press the "PAUSE" button, if you want to interrupt the working process.

Please remember the following safety precautions when working with this device:

A fire extinguisher must always be handy as the laser beam can ignite flammable materials. Do not store any flammable materials inside the device or in the immediate vicinity of the device. Particularly, leftovers of produced materials have to be removed to prevent fire hazard.

Unsupervised operation of the system is not permitted:

Because of their low absorption, many metals, in particular un-coated aluminum, copper, silver and gold cannot be processed with the laser and this leads to high reflections of the laser beam. Such materials must not be inserted into the beam, as a directed reflection could destroy the protection cover.

Adjustment of the beam path must be performed only by especially trained personnel. An improper setting can lead to uncontrolled emission of the laser radiation.

Before processing materials, the user must verify whether harmful materials can be generated and whether the filter equipment of the exhaust system is suitable for the harmful materials. We emphasize that it is the responsibility of the user, to consider the national and regional threshold values for dust, fogs and gases when selecting the filters and the exhaust system. (The values for the maximum workplace concentration must not be exceeded.)

Please refer to the manual of the exhaust system on how and in what intervals you need to replace filters.

PVC (polyvinyl chloride) must under no circumstances be processed with the laser.

Should you have further questions before you start working, please feel free to write us an email to: help@cs-supportpro.com

2.4 Warning and Information Labels



The warning and information labels are attached in such positions of the device that could represent a source of danger during set-up and operation. Therefore, follow the information on the labels. If labels are lost or damaged, they must be replaced immediately.

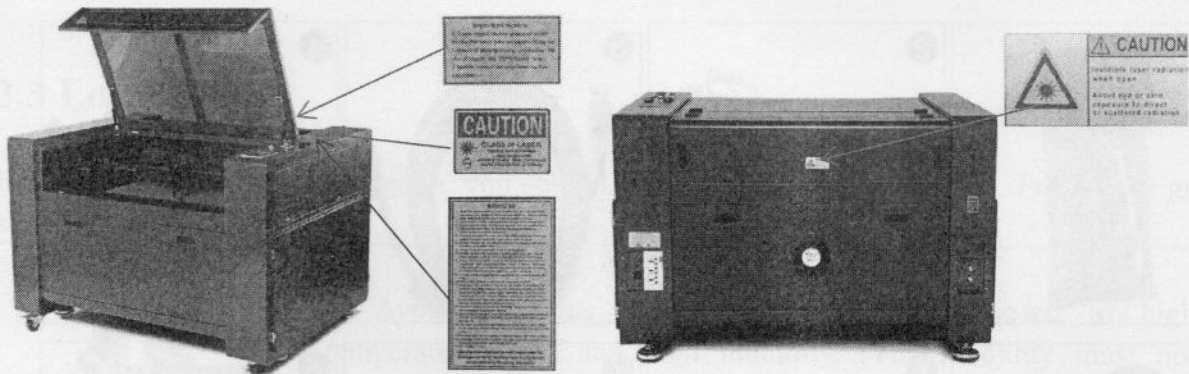

Chapter 3 Process of Installing

3.1 Unpacking

You receive your machine packed in a wooden box, which contains the laser machine and additional accessories. The following steps give you an overview of the unpacking and assembly of the laser. Please follow these steps carefully.

Tips

Keep the packing box. You will require it in case of a return.

Dispose all waste according to the applicable waste disposal law.

1. Put the wooden box on a flat and spacious room for unpacking.
2. Remove the machine box, and carefully remove the foam material, which protects the viewing window of the cover and around the machine.
3. Take out the key and open the door of the laser. Remove the accessories box which contains all accessory parts required for the installation of the laser machine.

And check if there's anything damaged or missed during shipping

4. Remove the sponge and nylon cable ties inside the machine and start to install the attachment, software and so on
5. Please keep these keys.
6. Remove the sponge and nylon cable ties inside the machine, and start to install the machine (see chapters below for installation details)

3.2 Contents of Delivery

1. Transport and service packaging
2. Laser including optics
3. Other optional components that you buy
4. Accessories box and the other machine parts, containing the following parts:

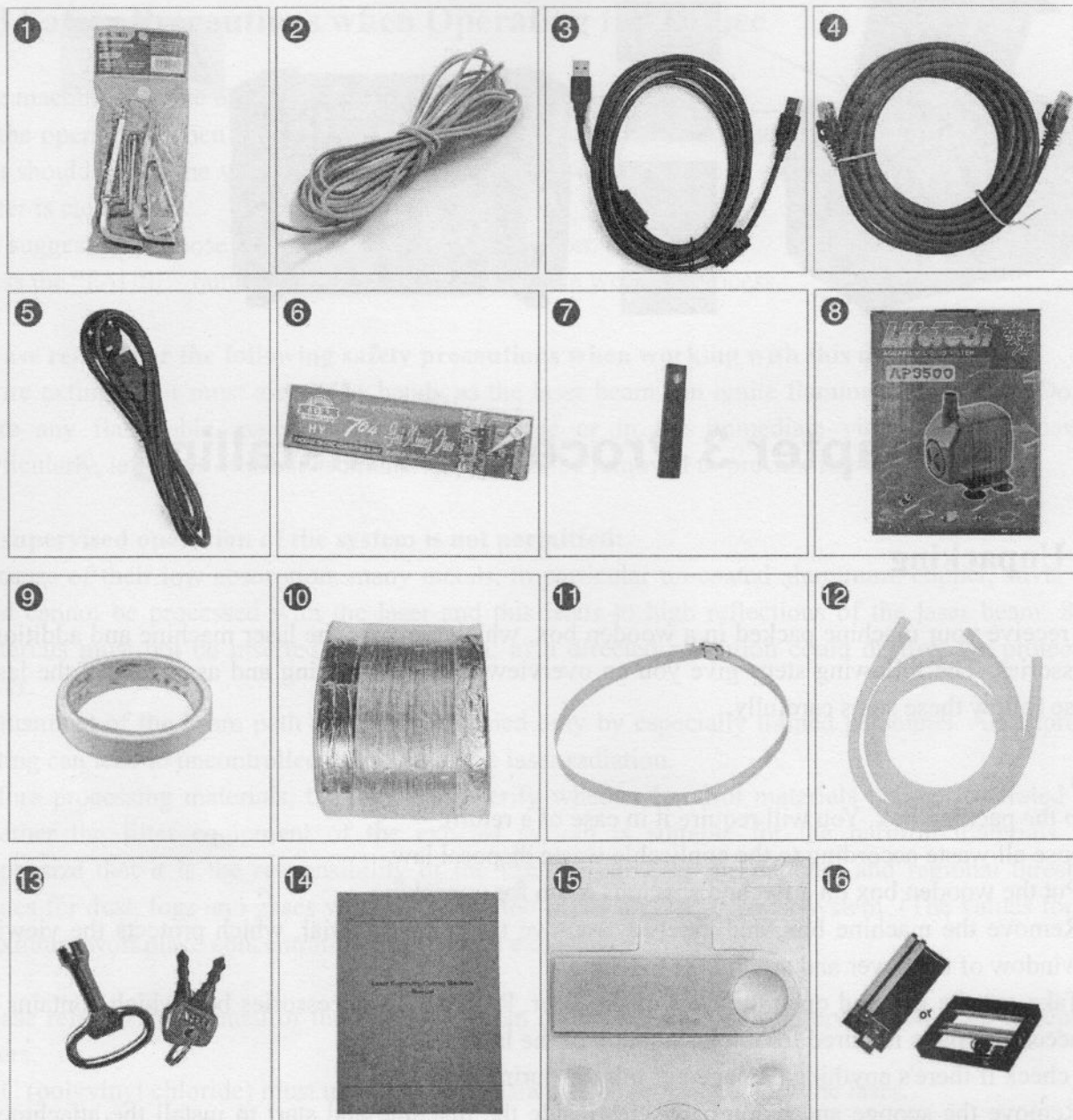



ITEM	QTY
1. tools	1
2. Ground Wire	1
3. Long USB Cable	1
4. Ethernet cable	1
5. Power Cable	1
6. silicone	1
7. 7mm acrylic focus tool	1
8. Water Pump/Water chiller	1

ITEM	QTY
9. Sticker for Adjust light path	1
10. Exhaust Pipe	1
11. Hose Clamp	1
12. Water Pipe	2
13. Key	1
14. Manual	1
15. 4G U-Disk (software)	1
16. The axis of rotation (optional)	1

3.3 Built-in Air Pump

3.3 Location

Before you install the laser system, you should select an appropriate location. Follow the guidelines shown below:

	<ol style="list-style-type: none">1. Avoid locations where the system is exposed to high temperature, dust and high humidity. (The humidity must not exceed 70% and the temperature must not be close to the dew point.)2. Avoid locations where the system is exposed to mechanical shocks.
	<ol style="list-style-type: none">3. Fuse protection: Do not connect other devices via the laser fuse, as the laser system requires the full amperage.

Tips:

1. Avoid locations with poor air circulation
2. Select a location, where room temperature is between 5 °C and 25 °C. Avoid higher ambient temperature and strong exposure of the engraver to the sun. Use blinds, if required.
3. Select a location close to ventilation (if available).
4. Select a location that is not more than 4.50 m away from your computer (max. cable length to avoid disturbing interferences).
5. Try to place a working table or a place to put things next to it. This shall avoid, that the machine is misused as a table.

3.4 Before Installation

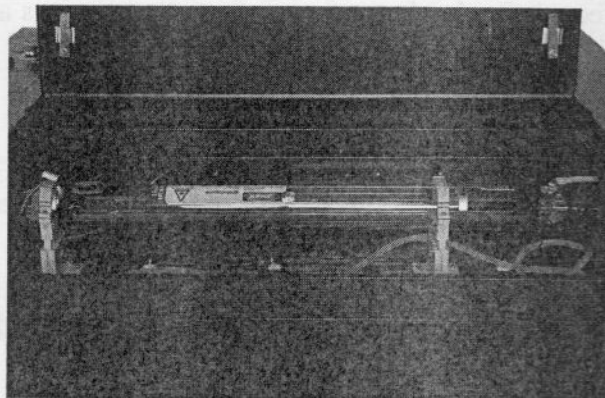

Take out the sponge around the laser tube

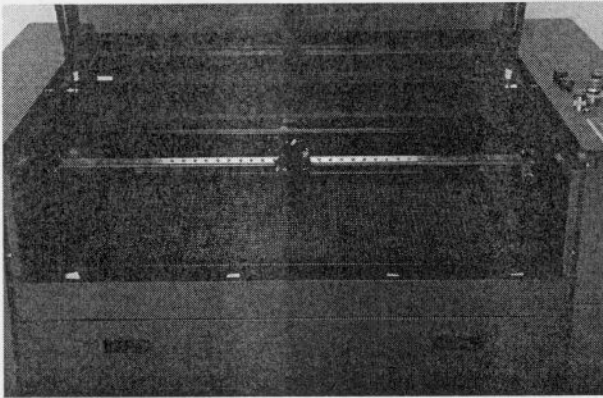

Take out the nylon cable ties around the honeycomb plate and X axis

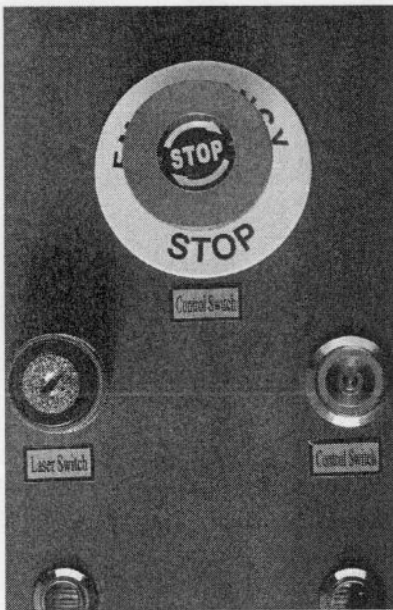

Open the rotary emergency switch (You must do it the first time you use the machine.)

3.5 Exhaust System – Requirements

To guarantee the right ventilation during the engraving and the cutting, the device must be equipped with a fine exhaust fan (generation of rubber dust). If you use a carbon filter (neutralize smells), it will be better for exhaust effect. A good exhaust fan of the outgoing air is also required when cutting plastics or engraving wood.

Connection - see section 3.8.3 connecting the Exhaust System.



Do not start the machine without an adequate exhaust system.

3.6 Built-in Air Pump

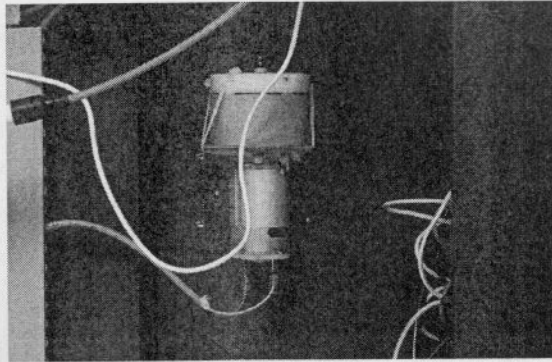

3.7 Computer – Requirements

The following recommendation represents the minimum requirements. When using a more powerful computer, the graphics are generated and displayed faster, and the computing times and the data transferring to the laser are reduced.

To use the newest software version, you might have to abide by other requirements.

Windows 8 (32 bit and 64 bit)

Windows 7 (32 bit and 64 bit)

Windows Vista (with Service Pack 1 or later)

Windows XP (with Service Pack 2 or later)

1024 MB of RAM, 400 MB of hard disk space

Pentium® 3 or 4 processor or AMD Athlon™ XP

1024 x 768 or better monitor resolution

1 free USB interface

1 free Ethernet interface

Mouse

3.8 Connections



Perform the connections exactly in the order described; otherwise electrostatic charging can damage your computer and/or the electronics of the laser system.

3.8.1 Connecting the Mains

Connect one end of the main cable with the connection socket at the rear side of the laser device (see Figure below) and the other end with a protected power outlet.



Main voltage and operating voltage must correspond (AC 220 V/50 Hz or AC 110 V/60 Hz). See information label beside the connection socket
Under no circumstances can you switch on the device if the voltages do not correspond.

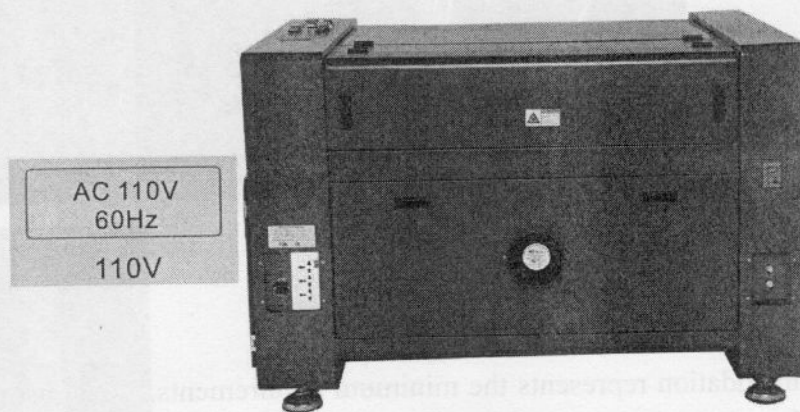

Tips:

The main fuses are located inside the connection socket and are accessible from the exterior.

3.8.2 Connecting the Computer

Connect the Computer and the machine by using the USB cable. Like below:

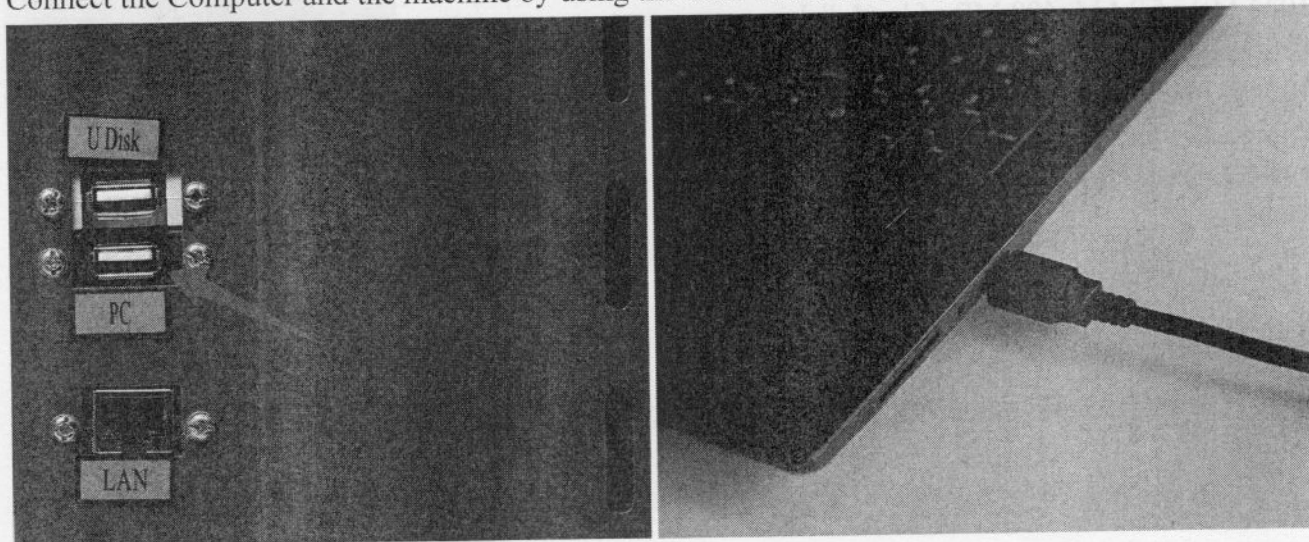

Connect the Computer and the machine by using the Ethernet cable. Like below:

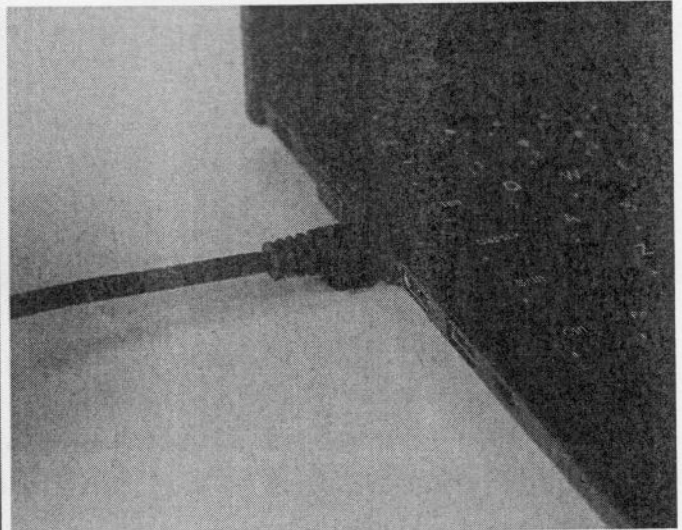
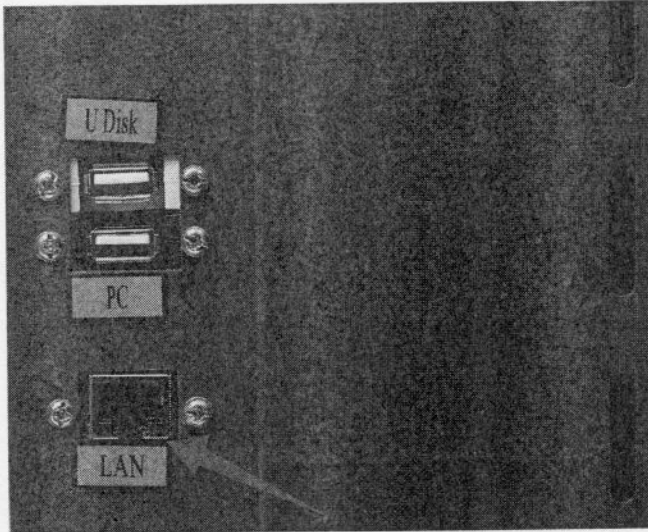

3.8.3 Connecting the Exhaust System

Exhaust fan, smoke pipe, is shown in Fig.

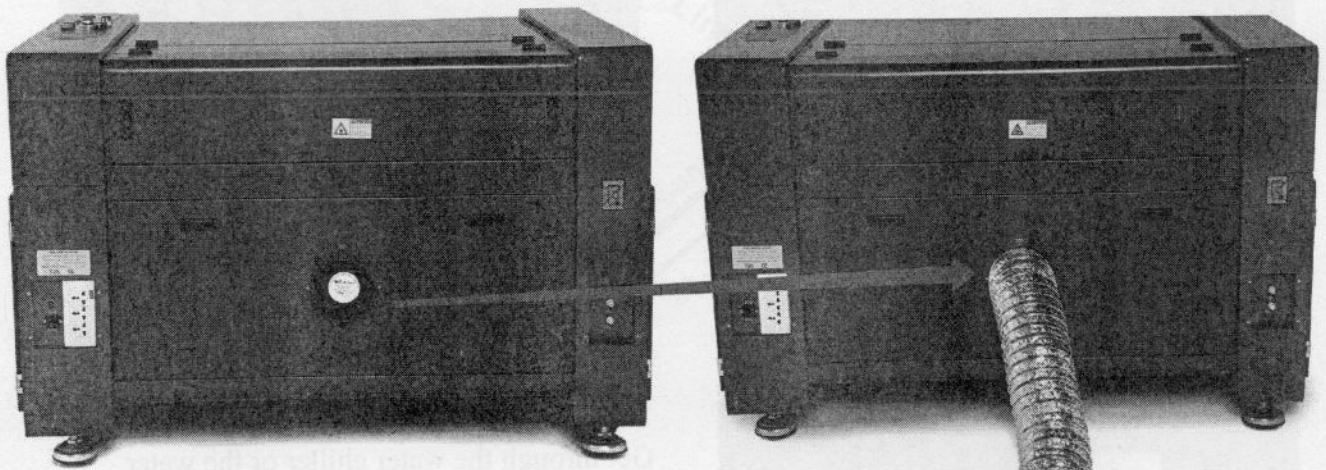

3.8.4 Connecting the Cooling System

If you have the water chiller, please connect to the water chiller priority. If not, please connect to the water pump.

The connection of the machine and the Water chiller

- ① Take out one of the water pipes. Connect it to the water chiller where marked as "OUTLET", and connect the other side of the pipe to the machine where marked as "Water IN".
- ② Please connect the other pipe to "INLET" of water chiller and "Water OUT" of machine.

We will provide a certain chiller power cable for different countries, and the power cable will be put inside a box together with the water chiller.

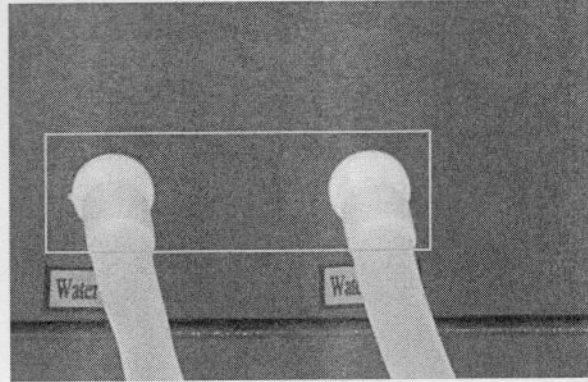
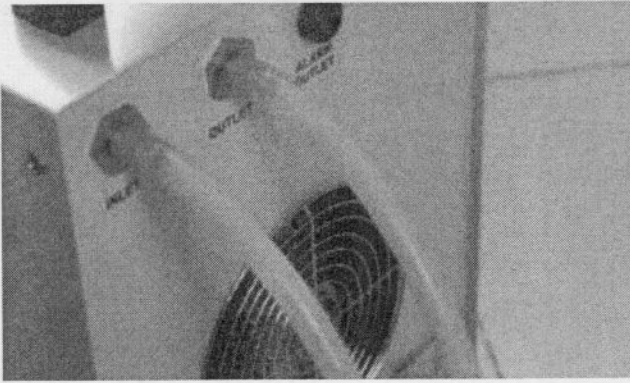

The connection of the machine and the water pump

Take out one of the water pipes. Connect it to the water pump, can the other side to the machine where marked as "Water IN".

Please connect the other pipe to the machine where marked as "Water OUT", and the other side directly into the water.

See below:

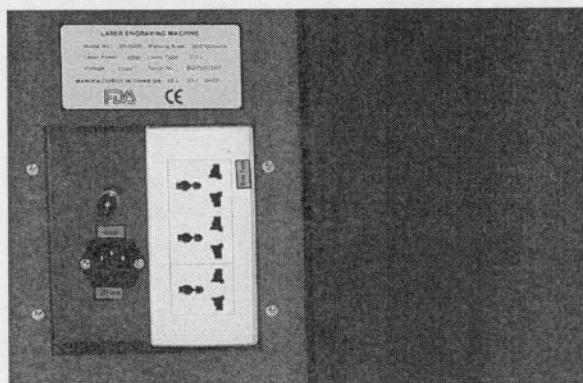
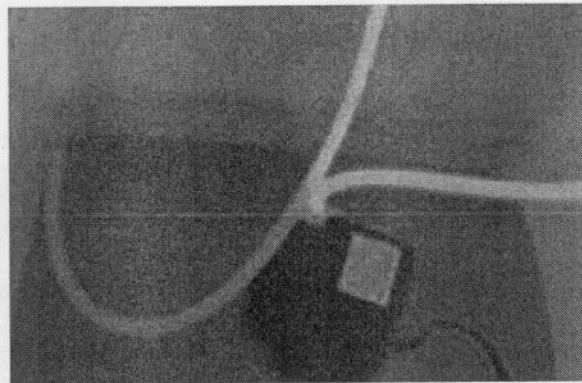
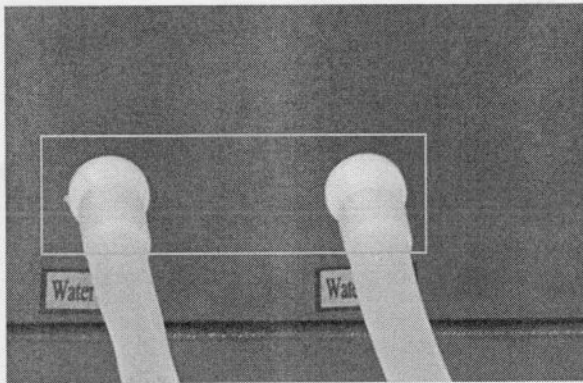

Get through the water chiller or the water pump, and turn on the main power.

Check the water chiller or pump to work (If normally works, the green light will be on or water will flow from the pipe).

3.8.5 Safety Grounding

Co2 laser tube is the fourth type of laser. The type of drive is high-voltage-driven, so when users use the machine, they must comply with the "Safety Note". On the other hand, it asks stringent requirement about the safety grounding to the users. The safe Line-to-Ground Resistance should be

less than 5. Specific connection method is shown in the below:

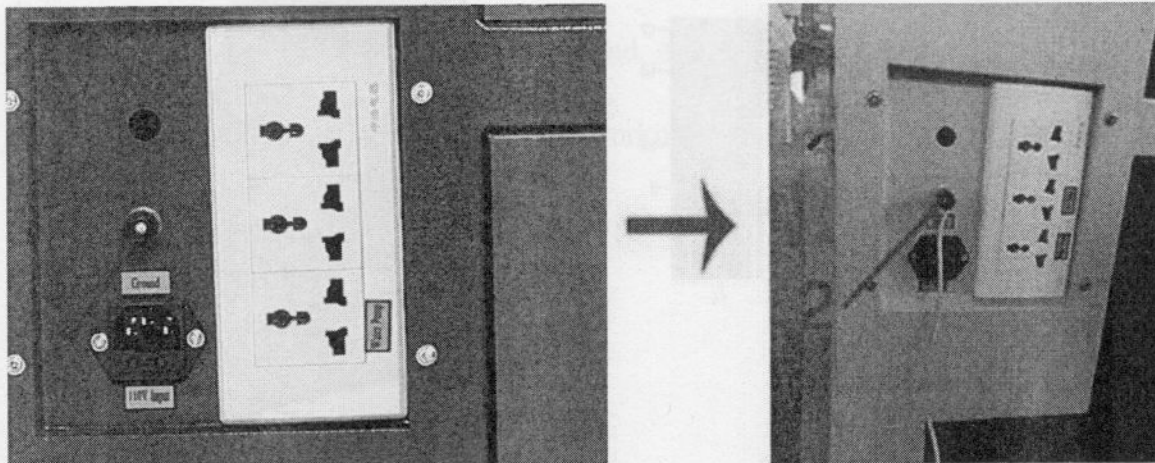

Ground wire is shown in the fig.

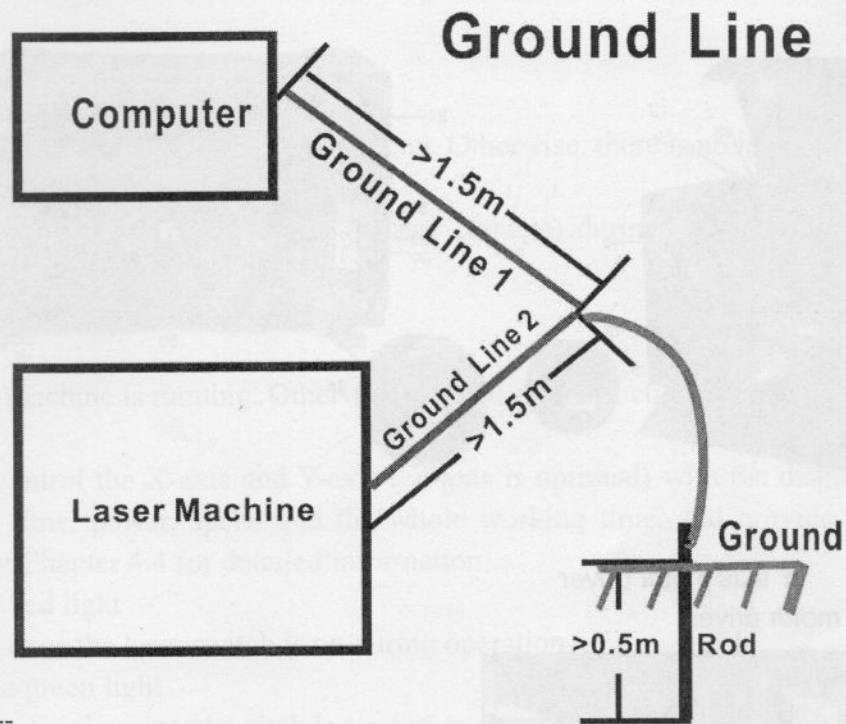

Chapter 4 Operation

4.1 Machine View

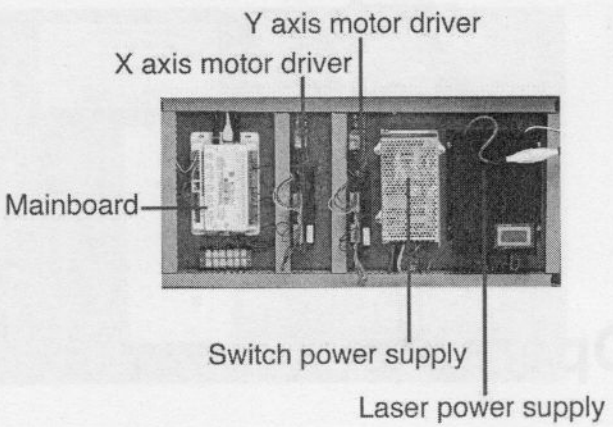
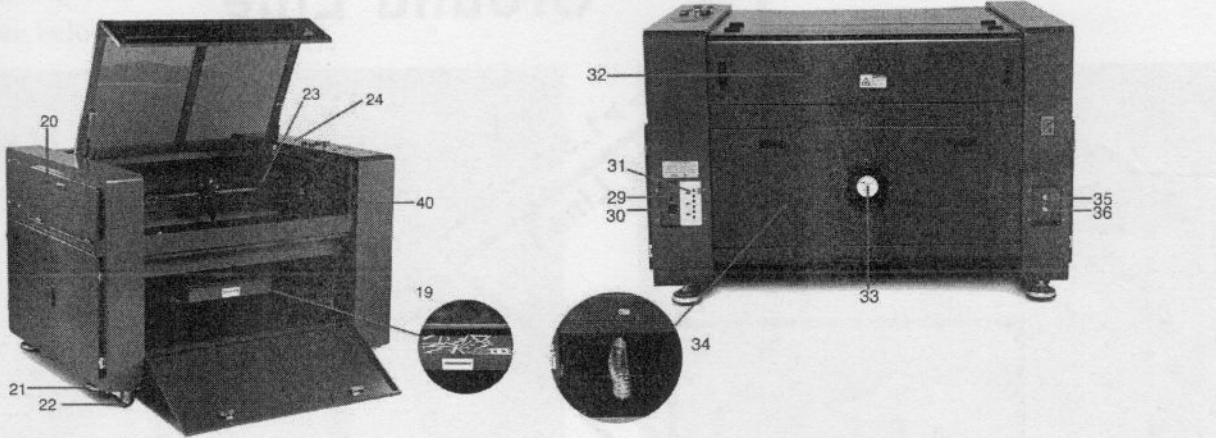
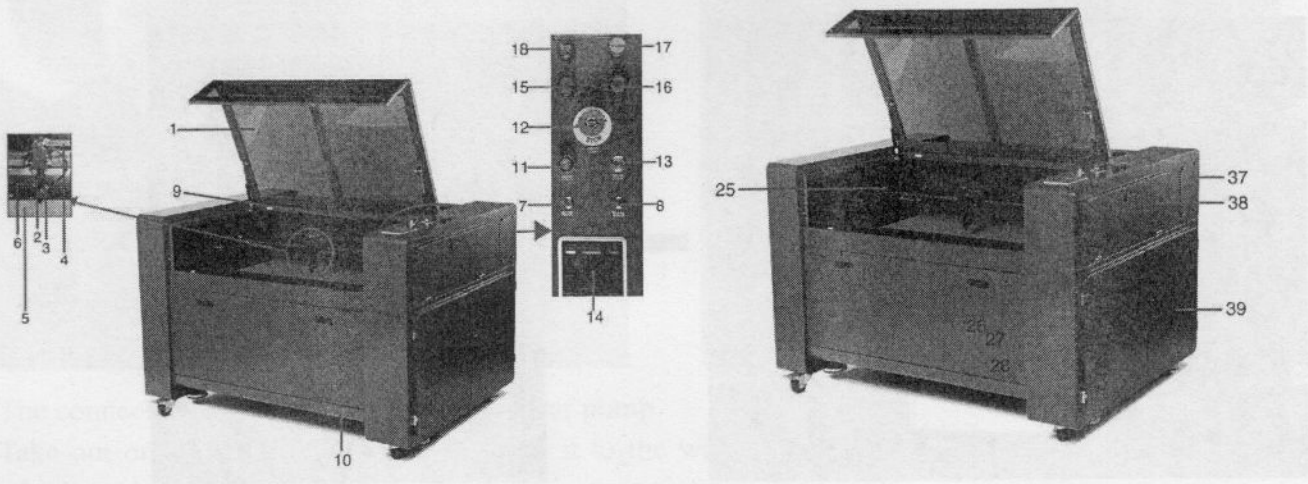

- 1: Top lid
Open the top lid when you put materials, and close the top lid when the machine is working.
- 2: Laser head
The laser and red dot pointer come out from the laser head.
- 3: Blow air conditioner

Blow away the smoke and dust, protect the lens, prevent the material from catching fire, etc.

4: Leading chain

There is an air pipe for blowing air for laser head. And there is red point cable in it.

5: Honeycomb working table (optional)

According to your need, put the honeycomb working table onto the aluminum knife working table or aluminum plate working table.

6: Red point

Used to indicate the position of the laser light.

7: Up button

Used to move the working table up.

8: Down button

Used to move the working table down.

9: LED light

You can easily see the situation of working.

10: Front door

There is a waster drawer inside.

11: Laser switch

Turn on the laser switch when the machine is running. Otherwise, there is no laser.

12: E-stop (The rotate emergency switches)

Once there's an accident (laser catching fire or laser leakage) during working, please turn off this switch immediately.

Run the machine, and make sure it is on.

13: Control switch

Turn on it when the machine is running. Otherwise, there is no instruction for the machine.

14: Control panel

You can manually control the X-axis and Y-axis (Z-axis is optional) with the display panel. It also shows the working time, power, speed and the whole working time, and provides many function options (please view Chapter 4.4 for detailed information).

15: Laser light – the red light

This light will flash once the laser switch is on during operation.

16: Power light – the green light

This light will flash once the control switch is on during operation.

17. Cover protection light – the orange light

The light will flash if the cover opens during the operation.

18: Cover protection alarm

The alarm will go off if the cover opens during the operation to remind you that the machine is in an unsafe condition. Close the cover to stop the alarm.

19: Waste drawer

Used to store waste generated during operation. Please clear the drawer frequently to keep it clean.

20: Upper left door

Open this door to clean the second reflective mirror.

21: Base foot

Support machine for working.

22: Wheels

These wheels make it easy to push the machine and change its position. When the machine is moved to the intended position, please make sure the two front wheels are fixed by pressing down the brake pads of the two omni wheels.

23: X limit switch

It will give a stop instruction to the motor when the laser head gets to origin.

24: Attention

Please read it carefully before running the machine.

25: Y limit switch

It will give a stop instruction to the motor when the laser head get to origin.

26: U-disk connection port (USB)

You can transmit data with the U-disk, and it is very useful for different situations.

27: USB cable port (PC connection port)

This USB is for connecting computer.

28: Ethernet port

This port is used to connect the laser machine and PC by Ethernet cable.

29: Ground line

This point is for connecting cable from machine to ground, and to make sure the machine works better.

30: Power supply socket

To connect the main power and the extend power according to the label information, and there are fuses in it.

31: Water pump power socket

You can connect the water pump to it when you do not have enough sockets on your workplace.

32: Laser tube cover

It's where the laser tube and the first reflective mirror are installed.

33: Exhaust hose

This is for installing the exhaust device.

34: Back door

Open the door and you can see the exhaust device and the electric lift motor. If there is any waste inside, please clean it frequently.

35: Water inlet

This port is for connecting water out pipe of water pump or water chiller.

36: Water outlet

This port is for connecting water in pipe of water pump or water chiller.

37: Preformed hole of the laser tube

Used to change for a laser tube with larger power.

38: Upper right door

Open this door to connect the socket of the rotation axis (the rotation axis is optional).

39: Lower right door

There is laser power supplier, main board, switch power supply, X and Y motor driver. Please open this door to check these parts. You must pay attention to the electric current.

40: Cover Protection

If the cover opens when the machine is operating, the machine will stop working

4.2 On/ Off Switch

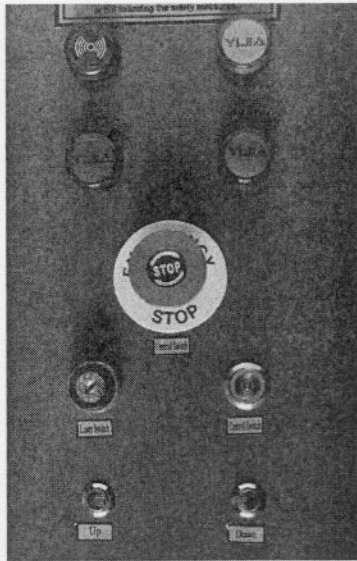

Switches the E-stop and the laser supply power ON/OFF

The following conditions must be fulfilled for correct start up:

- Unrestricted freedom of motion of the mechanics
- No materials under the engraving table
- When turning on the power of machine, turn on the E-stop switch first and then the laser supply power.

When the referencing process is completed correctly, there will be an acoustic signal sounds and the device is ready for operation. The operation panel will display the home screen when the laser is completely reset.

Before switching on the device, the user must make sure that no objects of any kind are located inside the operating space, which could limit or obstruct the mechanics of the device.

Tips:

When switching off the main supply, all processing data is lost.

4.3 How to adjust focus distance

For standard laser head:

Find the 7mm Acrylic Focus Tool for help to adjust the focus directly like below:

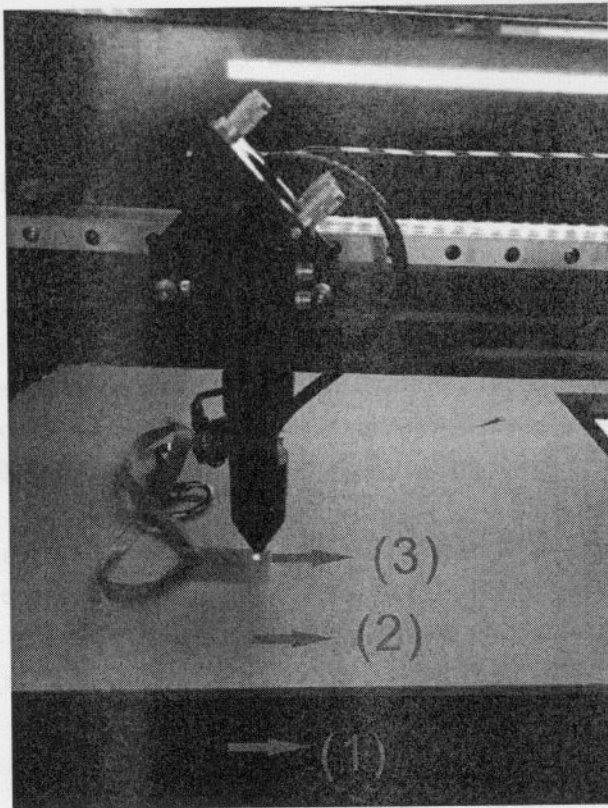

- (1) Working Table
- (2) Material
- (3) Focus Tool

4.4 How to use the control panel

4.4.1 Control Panel

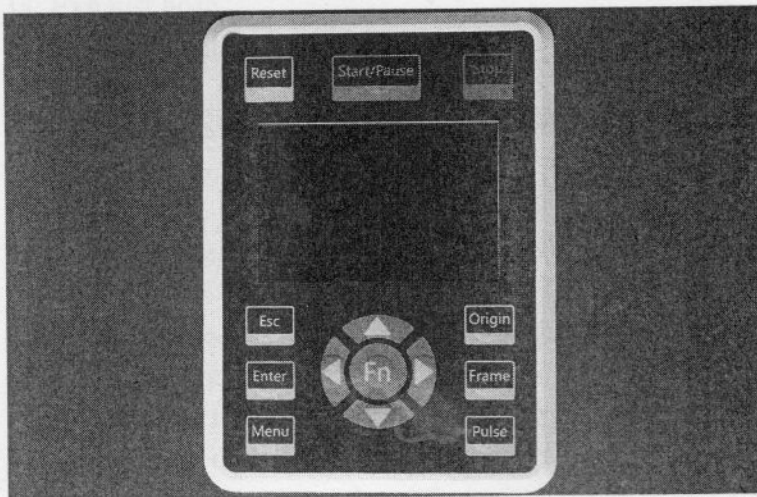

4.4.2 Function of the Buttons

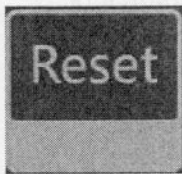

Reset button: reset the machine.

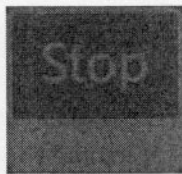

Stop button: stop the current job.



Start/Pause button: run/pause the current job.

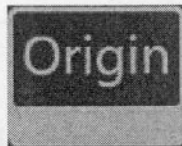

Origin button: set the starting point for the laser head.

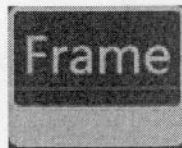

Frame button: track by the current file's frame.

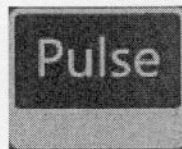

Pulse button: fire laser from the laser tube



Esc button: stop work or return to the previous menu.

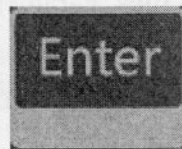

Enter button: confirm your selection.

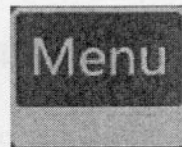

Menu button: set the speed, maximum and minimum power, and manage files.

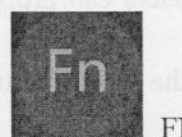

FN button: control Z-axis movement, and set the starting point and the language.



X+/- buttons: control X-axis movement, or move left and right to set parameters.



Y+/- buttons: control Y-axis movement, or move up and down to set parameters.

4.4.3 The Main Interface

When the system is powered on, the screen will show as below:

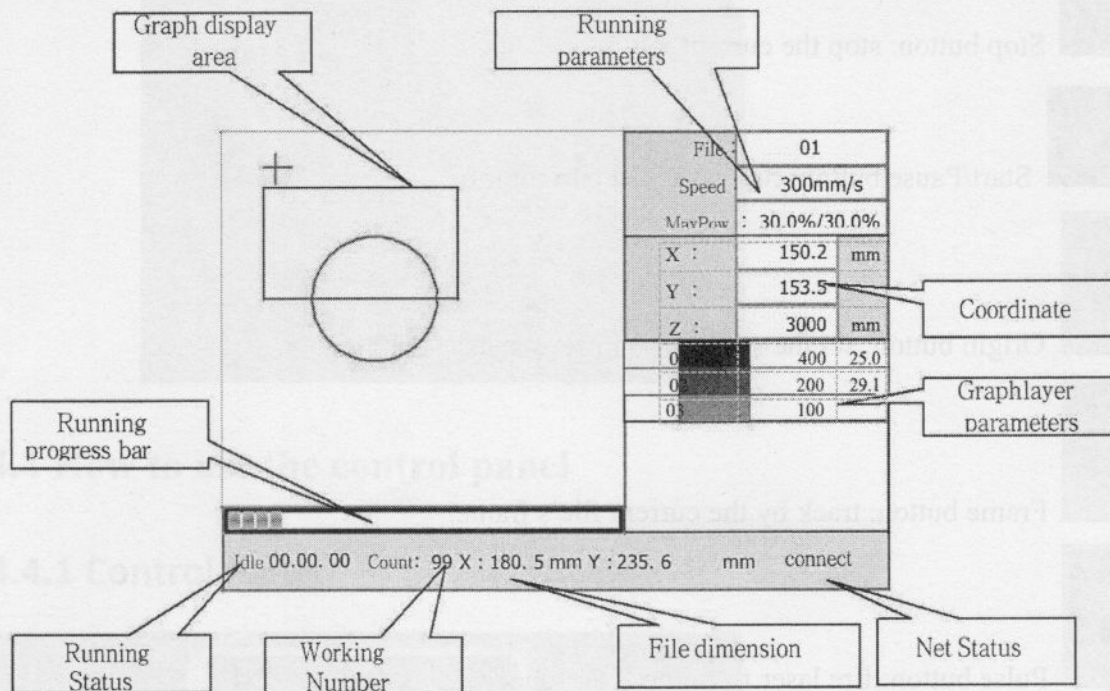

- Graph Display Area: to display the whole file's track and display the running track.
- Running Parameters: to display the running file's file number, speed, max power, etc.
- Coordinate: to display the current coordinates of the laser head.
- Graph layer parameters: to display the layer parameters of current or preview files. Parameters from left to right are layer number, color, speed, and maximum power.
- Running Status: to display the current status of the machine, such as Idle, Run, Pause, Finish, etc. Processing time is shown on the right side.
- Running Progress Bar: to display the progress of the current file.
- Working Number: to accumulate the work number of the current file.
- File Dimension: to display the dimension of the current file.
- Net status: to display the connecting status of the Ethernet.

When the system is idle or the work is finished, all the buttons can work. Users can process the file, set the parameters, preview the file, etc.

When the work is running or paused, some buttons will not work, such as the Origin button and Frame button.

4.4.4 Menu Button

Press the Menu button on the main interface to enter the Menu interface, as shown below:

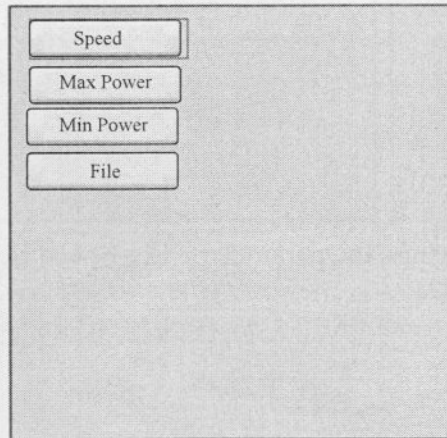

Push "Y+/-" keys to select items, and then press the Enter button to enter the corresponding sub-menu.

4.4.5 Speed

Select "Speed" on the menu interface, and the following dialogue box will appear:

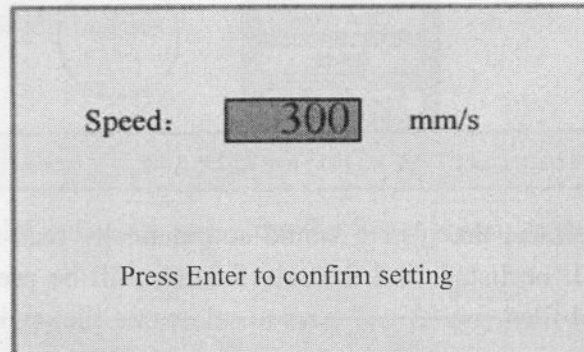

The cursor will appear when pushing "X+/-" keys. Move the cursor to the numeral area and push the "Y+/-" keys to change the value. Press the Enter button to save the change. Press the Esc button to invalidate the change and return to the menu interface.

4.4.6 Max/ Min Power

Select "Max Power" or "Min Power" on the menu interface, and the following dialogue boxes will appear:

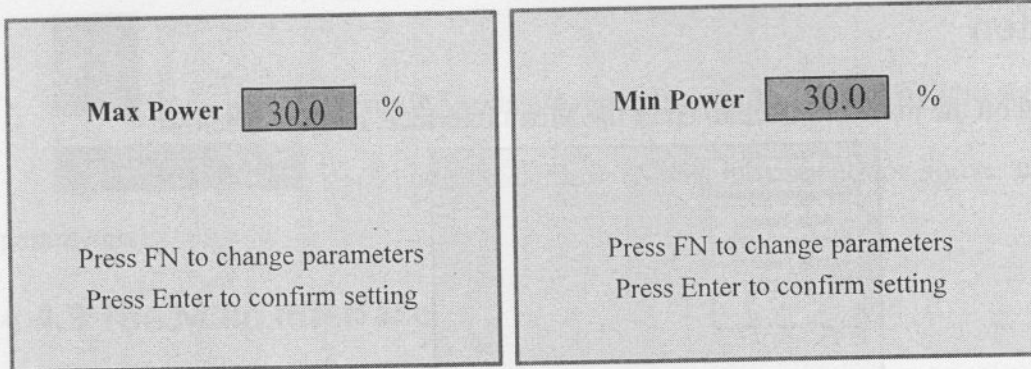

Push “Y+/-” and “X+/-” keys to change the parameters. See Speed Setting for reference.

4.4.7 File

Select “File” on the menu interface, and the following dialogue box will appear:

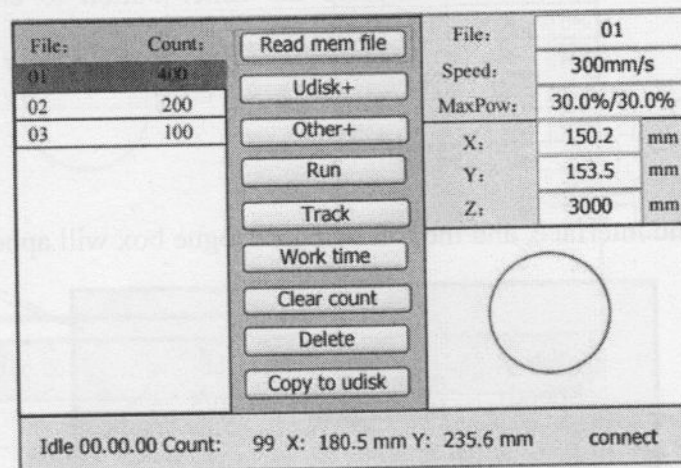

When entering the above interface, the system would automatically read the memory files. The file name and the work times will be listed, and the selected file will be previewed in the upper right corner. When there are several files, use “Y+/-” keys to select one file, and its preview will be shown in the upper right corner of the interface. Press the Enter button to preview the selected file on the main interface. Press the Esc button to close the preview.

Push “X+/-” keys, and the light blue cursor can be moved left and right to switch between file column in the left and item column in the middle. If the file is being previewed, the preview will be closed when switching to the item column. When the light blue cursor is on the item column, push “Y+/-” keys to select the item and press the Enter button to activate the item.

Press the Esc button to return to the main interface.

Items in the item column are as follows:

- Read mem file: to read the memory file list.
- U-disk: to read the U-disk file list.
- Other: other operations of the memory files.
- Run: to run the selected file. You can also press the “Start/Pause” button alternatively.
- Track: to track the selected file.
- Work time: to forecast the total running time of the selected file, and the time is accurate to 1ms.

- Clear count: to clear the count of the selected file;
- Delete: to delete the selected file in the memory.
- Copy to U-disk: to copy the selected file to U-disk.

Select “Other” and press the Enter button, and the following dialogue box will pop up:

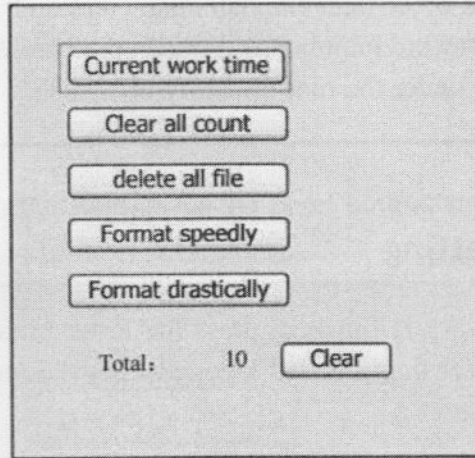

- Current work time: to forecast the running time of the current file.
- Clear all count: to clear the count of every file in the memory.
- Delete all files: to delete all memory files.
- Format speedily: To format memory speedily, after which all files in memory will be deleted.
- Format drastically: To format memory drastically, after which all files in memory will be deleted.
- Total: the total count of all the files.

4.4.8 U-disk File

Select “U-disk” on the “File” interface and press the Enter button, and U-disk file list will appear as shown below:

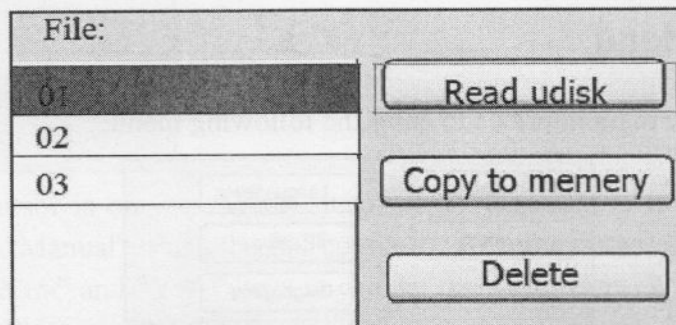

The operation method is the same as that of memory files. Press the Esc button to return to the “File” interface.

- Read U-disk: read the file list in the U-disk.
- Copy to memory: copy the target U-disk file to the memory.
- Delete: delete the selected U-disk file.

Notes

The system supports U-disk file formats such as FAT32 and FAT16, but files can only be identified when placed under the root directory of U-disk. File names with more than 8 characters will be automatically cut short. File names containing things other than English characters and numbers cannot be shown when copied to the mainboard. Files copied from the mainboard to U-disk will be placed under the root directory of U-disk.

4.4.9 Layer Parameter Setting

When the system is idle or the work is finished, press the Enter button to enter the layer parameter section. Push “Y+/-” keys to select the intended layer. Press the Enter button to check the selected layer's parameters as shown below:

01		400	25.1
02		200	29.1
03		100	31.5

Layer0

Speed mm/s

Min Power %

Max Power %

Press FN to change parameters
Press Enter to confirm setting

The light blue cursor will be on “Layer” by default. Push “X+/-” keys to select the intended layer. Press the FN button to move the light blue block to the intended parameter. Press the Enter button to save the parameter changes, otherwise changes will not be saved. The operation method is the same as that of the max/min power setting.

4.4.10 FN Button Menu

Press the FN button on the main interface to enter the following menu:

Z move	Language+
U move	IP setup+
Axis reset+	Diagnoses+
Manual Set+	Screen Origin+
Laser Set+	
Origin set+	
Set Fact Para	
Def Fact Para	
Auto Focus	

Push “Y+/-” keys to move the light blue cursor to the intended entry, and press the Enter button to enter the corresponding sub-menu.

4.4.11 Z Move

When the light blue cursor is on “Z move”, push “X+/-” keys to control the movement of the Z-axis.

4.4.12 Keyboard Lock

When the light blue cursor is on this item, press the Enter button, and the following dialogue box will pop up:

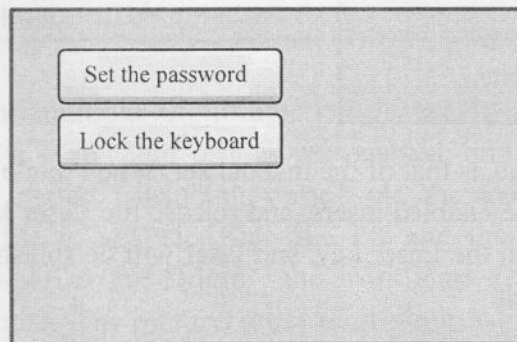

Push “Y+/-” keys to select items. When the light blue cursor is on the intended item, press the Enter button to enter the corresponding interface.

4.4.13 Manual Set+

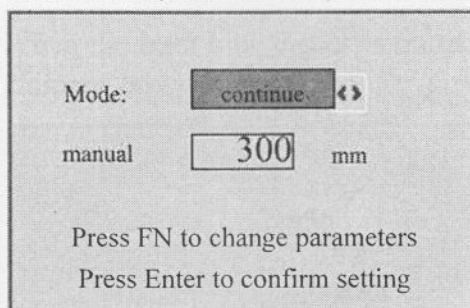

When the light blue cursor is on the “Mode” item, push “X+/-” keys to choose between the two modes “Continue” and “Manual”. Push the FN button to move the cursor. When the cursor is on the “Manual” item, push “X+/-” and “Y+/-” keys to change the parameters. When the “Continue” mode is selected, the “Manual” item will not be valid. In this case, press down the direction keys to move the corresponding axes, and release the keys to stop the moving. When it is in “Manual” mode, push the direction key, and the corresponding axes will move a fixed length as set by the users with each push (unless the scope is overstepped).

4.4.14 Laser Set+

When the light blue cursor is on this item, press the Enter button, and the following dialogue box will pop up:

Mode <>

Laser ms

Press FN to change parameters
Press Enter to confirm setting

The operation method is the same as that of the manual set. When mode “Continue” is selected, press down the Laser key to splash the enabled lasers, and release the Laser key to finish splashing. When mode “Manual” is selected, push the Laser key, and laser will be splashed for a fixed period of time as set by the users with each push.

4.4.15 Origin Set

When the light blue cursor is on this item, press the Enter button, and the following dialogue box will pop up:

Multi origin enable

Origin enable1 Origin enable3

Origin enable2 Origin enable4

Set origin: <>

Next origin: <>

Press FN to change parameters
Press Enter to confirm setting

Press the FN button to move the light blue cursor to the anticipant item, and when the blue block is on the “enable” item, press the Enter button to enable or disable the item. When enabled, the small box will be red, and when disabled, the small box will be grey. When the light blue cursor is on the “Set origin” item or the “Next origin” item, push “X+/-” keys to select the value. When changing the parameters of “Set origin”, remember to press the Enter button to validate the change. Parameters will be saved automatically when the interface is closed.

Details of each item are shown below:

→ Multiple Origins Enable: “Yes” or “No” can be selected. If you select “No”, the system will use the single-origin logic. You can press the “Origin” key and set the origin, and only this origin can become valid. If you select “Yes”, the system will use the multiple-origin logic and the “Origin” key

on the keyboard becomes invalid. In this case, the parameter of each origin must be set in the menu as follows.

→ Set Origin 1/2/3/4: After the multiple-origin logic is enabled, put the cursor on “Set as Origin 1/2/3/4”. Press the Enter button on the keyboard and the system will take the coordinates as the corresponding ones of the origin 1/2/3/4.

→ Next Origin: Users can choose from 0~4, which represent the origins to be used for the next figure. Origin 0 refers to the origin set by the “Origin” key under the single-origin logic. 1~4 represent the origins under the multiple-origin logic. The next origin can be chosen from origin 1-4 so as to control the starting point of the next job (provided that the origin is enabled.). However, it cannot be changed to origin 0 (the next origin will always be Origin 0 under the single-origin logic).

→ Origin Enable 1/2/3/4: After the multiple-origin logic is enabled, the four origins can also be individually disabled and enabled.

<i>Notes</i>	Once the multiple-origin logic is selected, if the serial number of the next origin is 1 and four origins are enabled, and when the memory file function is started (including started via the keyboard or PC), or the processing file is uploaded into the PC and this file selects “Take the Original Origin as the Origin”, the work started for each time will use different origins. The rotation order of origin is 1->2->3->4->1->2... If the processing file is uploaded to the PC and this file selects “Take the Current Origin as the Origin”, the system will always use the current origin.
--------------	--

4.4.16 Factory Parameter Setting

When the light blue cursor is on the “Set Fact Para” item, press the Enter button, and the following dialogue box will pop up:

Password :	<input type="text" value="123456"/>
Password error	
0 1 2 3 4 5 6 7 8 9	
A B C D E F G H I J	
K L M N O P Q R S T	
U V W X Y Z	

The password consists of six characters. Push “X+/-” and “Y+Z-” keys to select each character, and press the Enter button to confirm each selection. If the password is wrong, “password error” will pop up and you need to reenter the password. If the password is correct, the system will set all current parameters as factory parameters, and “factory parameters have been successfully set” will appear on the screen.

Notes	Before a machine leaves the factory, this function can be used to store the preset parameters, which later can be restored by users at any time.
--------------	--

4.4.17 Def. Fact Parameters

When this item is selected, the system will replace all current parameters with the default factory parameters.

The operation method is the same as setting the factory parameters.

4.4.18 Auto Focus

When the light blue cursor stops on “Auto Focus”, press the Enter button to automatically search for the focus.

4.4.19 Language

When the light blue cursor is on this item, press the Enter button, and the following dialogue box will pop up:



The operation method is the same as described above.

Press the Enter button when one language is selected, and then return to the main interface.

4.4.20 IP Setup

When the light blue cursor is on this item, press the Enter button, and the following dialogue box will pop up:

IP address:

Gateway address:

Press FN to change parameters

Press Enter to confirm setting

Press the FN button to move the light blue cursor to the intended item, and push “X+/-” and “Y+/-” keys to change the parameters. Press the Enter button to save the changes or the Esc button to discard changes and return to the previous menu.

4.4.21 Diagnoses

When the light blue cursor is on this item, press the Enter button, and the following dialogue box will pop up:

<input type="checkbox"/> X Limit+	<input checked="" type="checkbox"/> X Limit -
<input checked="" type="checkbox"/> Y Limit+	<input type="checkbox"/> Y Limit-
<input type="checkbox"/> Z Limit+	<input type="checkbox"/> Z Limit-
<input type="checkbox"/> U Limit+	<input type="checkbox"/> U Limit-
<input type="checkbox"/> Water prot1	
<input type="checkbox"/> Water prot2	
<input type="checkbox"/> Open prot	

This interface contains input/output information of the system’s hardware. Press the “Read para” button to access hardware information. When the hardware signal is triggered, the small box to the left of the corresponding item will be displayed in green, otherwise it will be grey. Press the Esc button to return to the previous menu.

4.4.22 Screen Origin

When the light blue cursor is on this item, press the Enter button, and the following dialogue box will pop up:

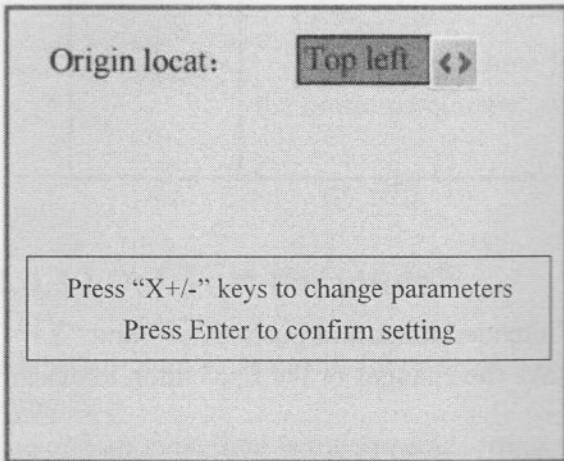

This interface shows the position of the **origin**. Different origin positions can generate different reflections of the graph over the X/Y axis.

The operation method is the same as described above.

4.4.23 Axis Reset

When the green block is on this item, press the Enter button, and the following dialogue box will pop up:

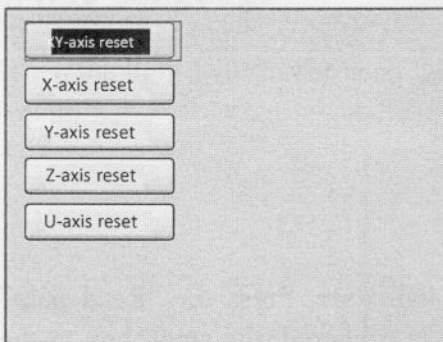

Push “Y+/-” keys to move the light blue block to the intended item. Press the Enter button to start the resetting of the selected axis, and a message of “resetting is underway” will show on the screen. Upon the completion of resetting, the message will automatically disappear and the system will return to the main interface.

4.4.24 Alarm Information

During the operation of the system or the running of the machine, some alarm information will pop up, including water protection error, hard limit protection, etc.

For example, alarm information regarding water protection error may pop up as shown below:

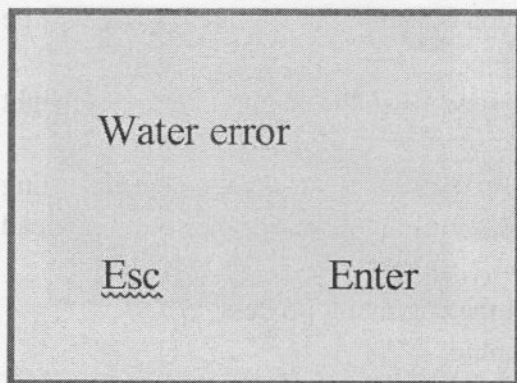

Press the Enter or Esc button, and the system will operate accordingly.

4.5 The First Time Running the Laser



1. Using the machine for the first time, and please note that the machine working voltage of 220V (110V for USA).
2. Please put the honeycomb on the standard table unless you need to engrave on thick material or use the rotary axis.
3. Lower the laser head, and the upper part of the head tube must be longer than 38mm
4. Please reset Z-axis after turn on the laser machine (watch the guiding video to learn how to reset the Z-axis, and refer to the operation video).
5. Please don't use the autofocus function if there's no materials on the table.

For example, first engraving tests

The following steps describe how to successfully engrave a first pattern. Please follow the individual steps:

1. First switch on the computer and the Laser.

Tips: When turn on the power of machine, and note that turn on the main switch first and then the laser supply power.

2. Put the object to be engraved into the laser and move into the desired position on the engraving table. Usually the object is positioned in the upper left-hand corner. Use the rulers to determine the dimensions of the object to be engraved.
3. With the positioning keys the lens is positioned over the material to be engraved. You focus with the help of the focus tool or by auto focus.
4. Generate a graphic with the help of your graphics software, or load in a picture that you want to engrave, but before this, you must click the Tort setting* in the software.

The size of the graphic does not matter as the printer driver adjusts it to the work piece automatically if requested.

If you have any questions, and also consult the Software Manual for further information.

5. Double-click the Work in the window of "Work", then you can modify the parameters such as speed, Min Power, Max Power, ramp Effect, Ramp Length, Interval and so on.

6. Select "download", you can change the file name. If you don't change the file name, that will be the default name for "default", and will be covered the last file.
7. Click "Origin" and "Frame" on the display, please make sure that the material is in the right location and there is enough space for working.
8. Please check the water cooling system is working property; the water is running into and filling the laser tube. Please do not start your work if the laser tube isn't full of water, because that may lead to laser tube damage due to the high temperature.
9. Finally press the "Start-Pause" button in the display, to start the engraving process.
10. While the laser is engraving, you can generate the next graphic.

When the engraving is complete, the laser machine will give out the notification sound and the laser head will go back to the original point. The warning light will return to the green light, and then you can repeat engraving.

4.6 Rotary Axis Attachment

The rotary axis attachment option in the printer driver is used in combination of the rotary axis attachment to engrave cylindrical objects. To compensate for the different diameters of different objects, the image must be adjusted. This is performed automatically by the engraving driver, by selecting the rotary engraving option and entering the diameter of the object to be engraved.

The Rotary size:

Cylindrical rotary device enables you to work on any cylindrical objects (diameter: 0.8"-6")

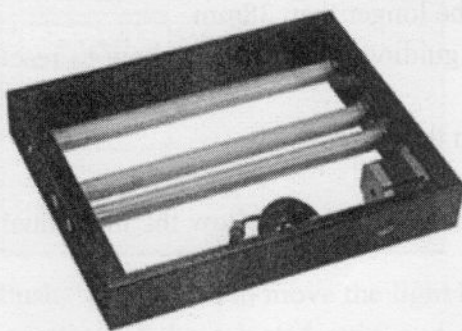

OR

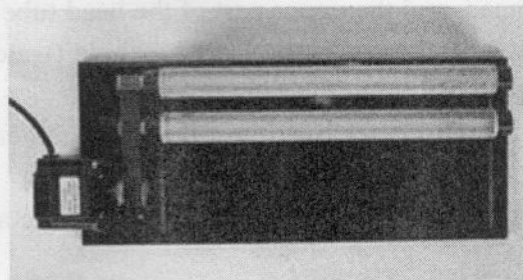

To install and set up the rotary axis attachment, proceed as described as follows:

1. Move the working table to the lower position, switch off the laser and open the top lid
2. Put the rotary axis attachment onto the working table and connect the rotary axis attachment to the working table. Before you fix the rotary axis attachment, align it so that its sides are parallel to X axis and Y axis of the machine.
3. Connect the rotary axis attachment via the control cable with the connector of the motion system. The connector is located inside the right front of the laser. Connect it to this interface and fix. Then, turn on the switch and reset the rotary device by pressing the "reset" button on the display. At last, you have finished the device connection. Like below:

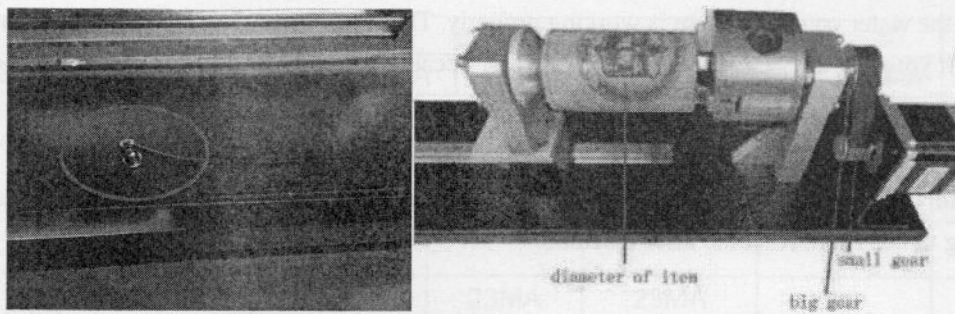

To install and set-up the rotary axis attachment, proceed as described as follows:

1. Move the working table to the lower position, switch off the laser and open the top lid
2. Put the rotary axis attachment onto the working table and connect the rotary axis attachment to the working table. Before you fix the rotary axis attachment, align it so that its sides are parallel to the rulers. The rulers offer a visual aid for placing the graphic.
3. Connect the rotary axis attachment via the control cable with the connector of the motion system. The connector is located inside the right front of the laser. Connect it to this interface and fix. Then, turn on the switch and reset the rotary device by pressing the “reset” button on the display. At last, you have finished the device connection. Like below:
5. Adjust and fix the slider to make the work piece fit into the rotary axis attachment
6. Now switch on the laser and wait until the referencing is finished. Position the working head over the object at the position, where you want to engrave. Now focus the object with the focus tool or by auto focus.
7. Generate a graphic with the help of the graphics software. The graphics size must be adjusted until less than the dimensions of the work piece.
8. Select “Output”, then input the diameter of the object and the circle pulse. Like below:

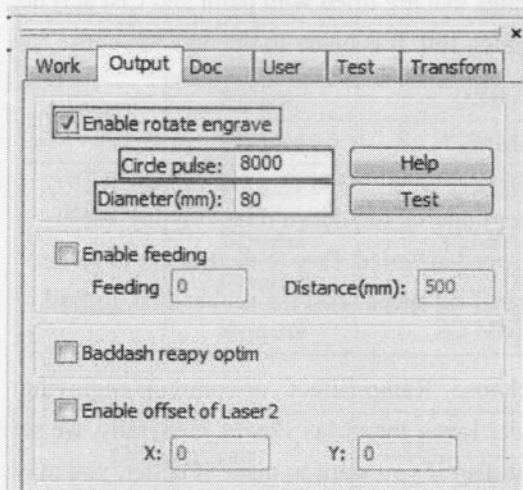

Select “Output”, and then tick “Enable rotate engrave”

- ① The Circle pulse is set to 8000
- ② The diameter of the target item

9. Select “download”, and click “Original” and “Frame” on the display. Please make sure that the material is in the right location and there is enough space for working.

10. Switch on the cooling system, and connect the exhaust system and the air pump to behind of the

laser. Please check whether the water cooling system is working properly. The water is running into and filling the laser tube. Please do not start your work if laser tube isn't full of water because that may lead to laser tube damage due to high temperature.

11. Finally press the "Start-Pause" button in the display to start the engraving or cutting process

12. When you don't need to use the rotary axis attachment to work, please turn the rotary axis switch off and remove it out of the working table. Then, reset the laser machine.

4.7 For Laser Engraving

The engraving depth can easily be varied through the laser power or the speed. To increase the engraving depth, reduce the speed or increase the power setting. This way you increase the amount of energy per area unit. Engraving too deep, however, reduces the quality of the details. With coated materials, the required power depends on the kind and thickness of the coating. With power set too high, the individual lines become too thick and a sharp picture cannot be achieved. The resolution of the graphics should usually be at 500 dpi. The dpi setting (number of laser dots per inch) depends on the material. The lower this setting is, the lower the resolution of the engraved picture will be. This, however, reduces flaming and increases the energy of a pulse, which can improve the overall result (e.g. when engraving some sorts of plastic materials).

1. Plastics

Plastics for engraving are available in many different colors and thicknesses and with many different coatings and surfaces. The majority of available plastics can be well engraved and cut with the laser. Plastics with a micro-porous surface seem to give the best result, because less surface material needs to be removed. As most plastic materials have a low melting point, a low pip setting should be selected to reduce the danger of melting.

2. Acrylic

There are two different types of acrylic - cast and extruded. The cast acrylic becomes white or mat after engraving, and the extruded acrylic remains clear. Use extruded acrylic for engravings that are filled with paint and cast acrylic for normal engravings. Cast acrylic can be best engraved without protection foil. It is better to engrave the entire surface with a low energy setting.

4. Engrave the rubber material

The various mixtures and densities of rubber plates cause a slightly varying engraving depth. The settings in the overview table give a good indication. Since engraving a standard rubber material requires a relatively high laser power, the laser power is principally set to 50% or higher and only the speed is varied. Due to their lower density, so-called micro porous rubber materials allow a significantly higher engraving speed. Test the rubber first, to find out the correct speed setting.

The RDWorksV8 software uses the engraving function, and you can choose "Ramp Effect" or common engraving. Once you choose "Ramp Effect", you will need to set a minimum power lower than Max Power. Generally, we set it to about 15%, and input a value with the Ramp Length that you want. But if you want to make it better, you may need to test different kinds of power and speed by yourself. Then, you can get the best result. Engraving rubber produces a considerable amount of dust and terrible gas. Therefore, a well-dimensioned exhaust system and its regular maintenance are very important Laser Processing Parameters for Different Materials.

Laser Processing Parameters for Different Materials

Power and speed are regulated by software. You can set up them in the software. Current in Ammeter is controlled manually.

Power	%	20	30	40	50	65-75	80	90	100
Current	MA	6MA	10MA	12MA	15MA	18MA	23MA	25MA	30MA

Description		Cutting Thickness of Acrylic					
		3mm	5mm	10mm	15mm	20mm	30mm
60W	Power	23MA	23MA	23MA			
	Speed	8MM/S	3MM/S	1MM/S			
80w	Power	23MA	23MA	23MA	23MA	23MA	
	Speed	12MM/S	5MM/S	2MM/S	1MM/S	0.7MM/S	
100w	Power	23MA	23MA	23MA	23MA	23MA	
	Speed	20MM/S	12MM/S	4MM/S	2MM/S	1MM/S	

Description		Cutting Thickness of MDF		
		3mm	5mm	10mm
60W	Power	23MA	23MA	
	Speed	5MM/S	3MM/S	
80w	Power	23MA	23MA	
	Speed	8MM/S	4MM/S	
100w	Power	23MA	23MA	23MA
	Speed	13MM/S	8MM/S	2MM/S

Description		Cutting Thickness of Plywood		
		3mm	5mm	10mm
60W	Power	23MA	23MA	
	Speed	12MM/S	3MM/S	
80w	Power	23MA	23MA	
	Speed	15MM/S	7MM/S	
100w	Power	23MA	23MA	23MA
	Speed	20MM/S	12MM/S	2MM/S

Description		Cutting Thickness of Rubber		
		3mm	5mm	10mm
60W	Power	23MA	23MA	
	Speed	12MM/S	4MM/S	
80w	Power	23MA	23MA	
	Speed	15MM/S	8MM/S	
100w	Power	28MA	28MA	
	Speed	30MM/S	30MM/S	

Description		Cutting Thickness of Leather			
		1mm	3mm	5mm	10mm
60W	Power	15MA	20MA	20MA	
	Speed	20MM/S	10MM/S	6MM/S	
80w	Power	12MA	15MA	18MA	20MA
	Speed	50MM/S	12MM/S	8MM/S	2MM/S
100w	Power	18MA	18MA	18MA	20MA
	Speed	50MM/S	28MM/S	12MM/S	4MM/S

Description		Cutting Thickness of Paper Board				
		0.3mm	0.5mm	1mm	1.5mm	2mm
60 W	Power	8MA	10MA	12MA	15MA	15MA
	Speed	300MM/S	300MM/S	200MM/S	200MM/S	160MM/S
80 w	Power	8MA	10MA	13MA	18MA	16MA
	Speed	400MM/S	400MM/S	300MM/S	300MM/S	200MM/S
10 0w	Power	6MA	8MA	12MA	12MA	16MA
	Speed	120MM/S	120MM/S	130MM/S	130MM/S	100MM/S

Description		Cutting Thickness of Cloth	
		0.3mm	0.5mm
60W	Power	10MA	12MA
	Speed	50MM/S	40MM/S
80w	Power	8MA	10MA
	Speed	70MM/S	60MM/S
100w	Power	6MA	8MA
	Speed	150MM/S	140MM/S

Chapter 5 Maintenance

5.1 Cleaning the Laser Machine



1. Caution - Use of controls or adjustments or performance of procedures other than those specified herein may result in hazardous laser radiation exposure.
2. Before starting cleaning and maintenance work, always switch off the device and unplug the main plug.
3. Always keep the system clean, as flammable parts in the working area or exhaust area rise the fire hazard.

Tips:

You should check at least once a day, whether dust has accumulated in the engraving system. In case of soiling, the machine must be cleaned. The cleaning interval strongly depends on the material that is being processed and the operating time of the device. Please bear in mind that only a clean machine guarantees optimal performance and reduces the service costs.

General Cleaning Notes:

1. Make sure that the device is switched off and unplugged. Open the protective cover.
2. Move the working table into a position in which it is easier for you to clean the surface with a window cleaning agent and paper towels.
3. Thoroughly remove all dirt particles and deposits in the interior of the machine
4. Clean the cover of the laser tube
5. You can clean the viewing window with a cotton cloth. Do not use paper towels as they could scratch the acrylic.

5.2 Cleaning the Optical Parts

The lens has a durable multi-coating and won't be damaged by correct and careful cleaning.

You should inspect the focus lens, the mirrors, and the beam combiner according to the maintenance plan. If you discover a veil of haze or dirt you must clean them.

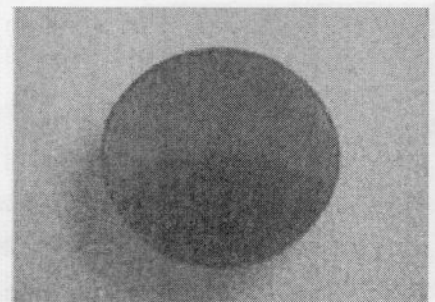
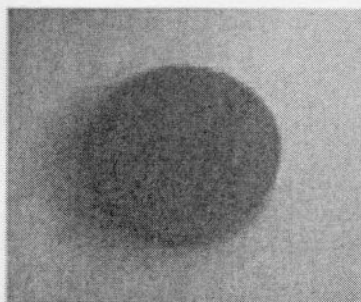

It is suggested to clean the mirrors/lens before work every day in order to run the machine at max efficiency.

Follow the instructions below for the cleaning of optical parts:

5.2.1 Cleaning the Focus Lens

1. Move the engraving table to a distance approx. 10 cm under the lens holder.
2. Move the working head into the center of the working surface and put a cloth under the lens holder (so that the lens is not damaged if it accidentally falls out of its holder).
3. Now, you can unscrew the lens holder.
4. Once positioned over a clean lens cleaning tissue, remove the lens from the lens holder by carefully turning the lens holder and letting the lens and the O-ring drop onto the cleaning cloth.
5. Examine the O-ring, and if necessary, clean it with a cotton bud and a lens cleaning tissue/cloth
6. Remove the coarse dust as good as possible by blowing air onto the lens surface.
Check the surface and if necessary clean the lens with the lens cleaning liquid and lens tissue/cloth
8. Hold the lens assembly by its edge with a lens cleaning tissue and use a drop of lens cleaning liquid. While holding the lens on an angle, flush both surfaces to wash away coarse soiling.
9. Put the lens on a clean lens cleaning tissue and put some lens cleaning liquid on one side of the lens. Leave the liquid to take effect for approximately one minute and then gently wipe it away with lens cleaning tissues soaked with lens cleaning liquid.
10. Finally, dry this side of the lens with dry lens cleaning tissues/cloth and repeat the cleaning process on the other side of the lens. Never use a cleaning tissue twice.
Dust accumulated in the cleaning tissue could scratch the lens surface.
11. Examine the lens. If it is still soiled, repeat the cleaning process until the lens is clean.
12. Carefully insert the lens into the lens holder and ensure that the rounded side (= convex) of the lens is facing upwards. Then, put the O-ring on top of the lens.
13. Carefully assemble the lens in reverse order

How to take out the focus lens? Please just do as the following pictures indicate:

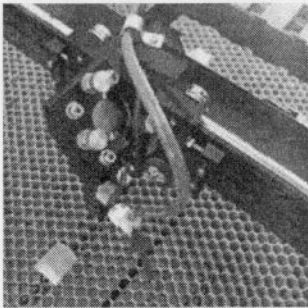

1. Remove the air pipe

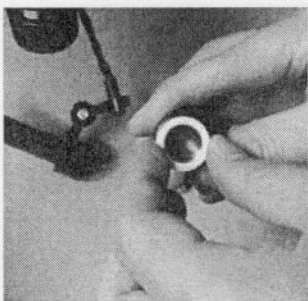

2. Rotate to the left, and the head is divided into two parts

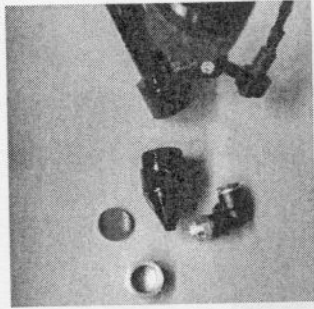

3. Install and please concave downward (convex side of the lens is facing upwards)

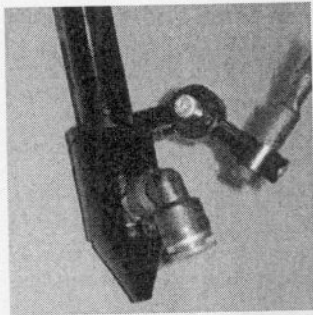

Fix back the focus lens, be careful not to scratch the lens, and then merge both parts together

5.2.2 Clean the Mirrors

There are three mirrors in the operating area of the laser, which may have to be cleaned if they are soiled. To clean the reflector, follow the instructions below.

The Mirror#1

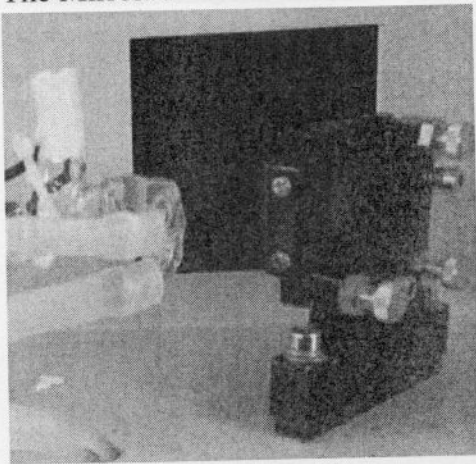

The mirrors are easy to be dirty. And this will reduce the efficiency of the laser beam. Meanwhile, laser energy absorbed by the mirror may cause heat and destroy the mirrors, too. For the first mirror, you can clean it directly.

The Mirror#2

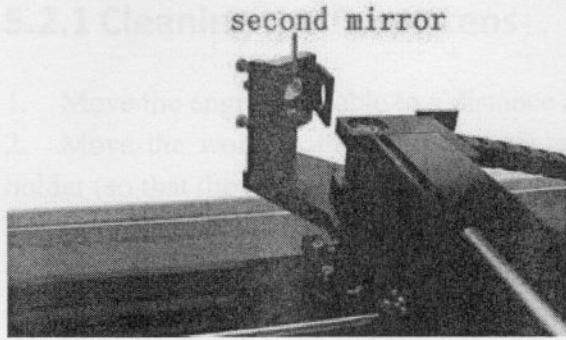

Make sure that the power of the laser machine is turned off while cleaning. The 2nd mirror is installed on the left side of X rail. For the second mirror, you can clean them directly.

The Mirror#3

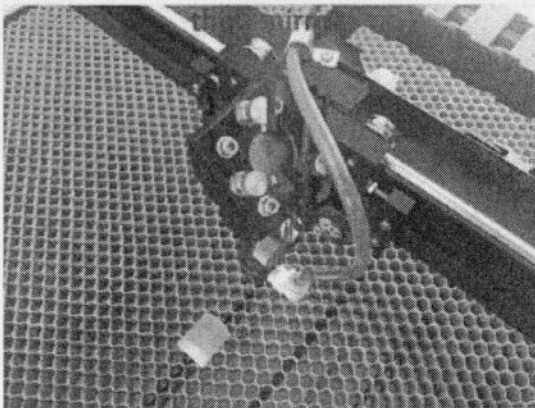

Cautions:

- 1) Mirrors must be cleaned carefully by using lens cleaning paper/lens cleaning cloth to avoid scratching the surface.
- 2) Do not touch the surface of the mirrors/lens after cleaning
- 3) The concave side of the lens must be on the bottom when installed.

How to take out mirror#1 #2 and#3? Please do as following pictures indicate:

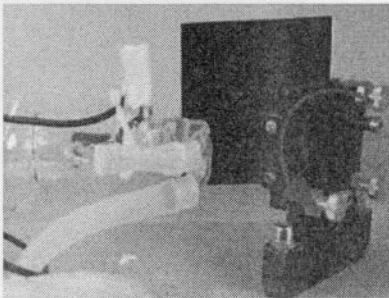

1. The mirror#1

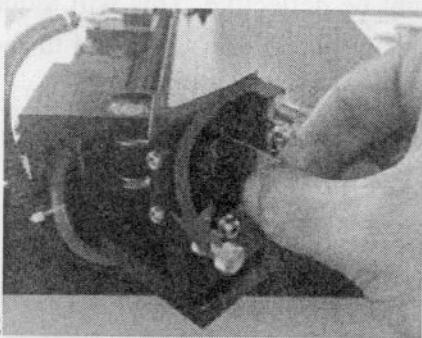

2. The mirror#2

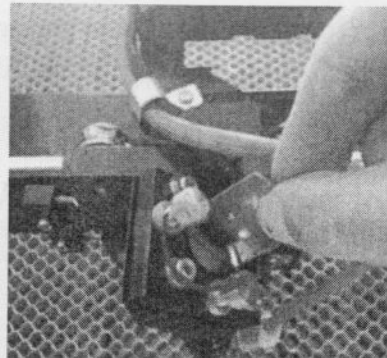

3. The mirror#3

5.3 Maintenance the X/Y Rails

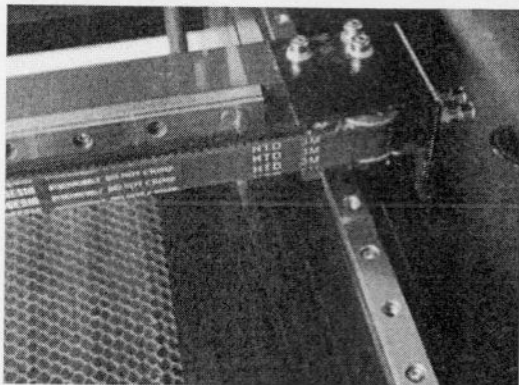

It is suggested to add lubricant oil (or Rust Preventative Grease) to the rails/screws at least every two weeks.

5.4 Check the Beam Path

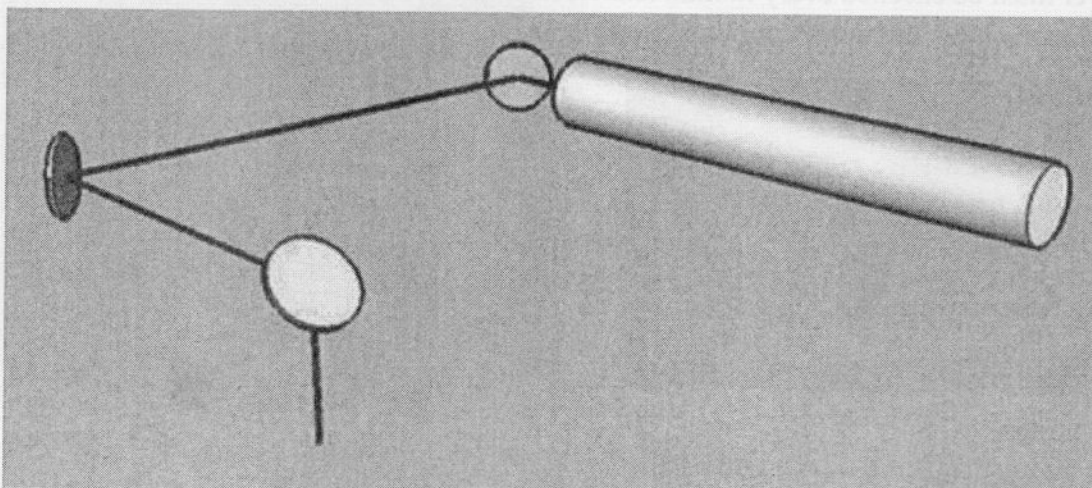

After being used for a long time, the beam path might be deflective. This will reduce the efficiency of the laser beam or even cause no laser beam. At this moment, you will need to re-adjust the beam path again.

5.5 Change Cooling Water for the Water Chiller



It is suggested to change the water at least once every month and make sure the laser tube is filled with water before starting the machine. It is advised to add water every 3 days.

The quality and temperature of the cooling water affects the life time of the laser tube.

You need to use pure (distilled) water and control the temperature below 35°C (95 °F).

5.6 Maintenance Plan

1. The lens and the mirror#3 must be checked daily, and cleaned if required.
2. The mirror#1 and the mirror#2 must be checked every month, and cleaned if required.
3. The working table must be cleaned daily.
4. The whole laser machine must be cleaned every month.
5. The exhaust system must be checked every week, and cleaned if required.
6. The air blower must be checked every month, and cleaned if required.
7. The other component (as the water cooling system) must be checked every month, and cleaned if required.

5.7 Maintenance Plan

Below are some solutions to this problem, and we advise that customers consult the following thinking before encounter problems, and hope customers can revise our thinking at any time. Laser head impacts limit switch while resetting.

Here are the fault factors:

1. Wrong pulse settings
2. Limit switch type mismatches the laser controller.
3. Wiring mistake

5.8 Cover Protection

If the cover opens when the machine is operating, the machine will stop working and you will see the screen shows below:

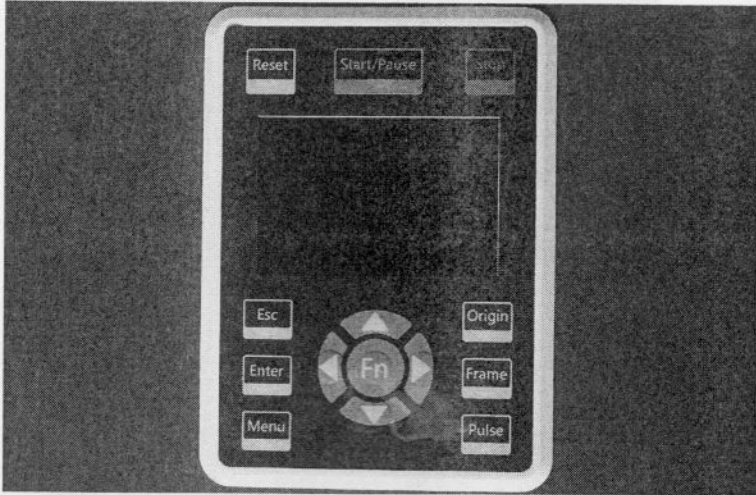

Press "Enter" on the screen and the machine will start working again.

5.9 Digital Display Power Supply

5.9.1 Images

Embedded LCD Type

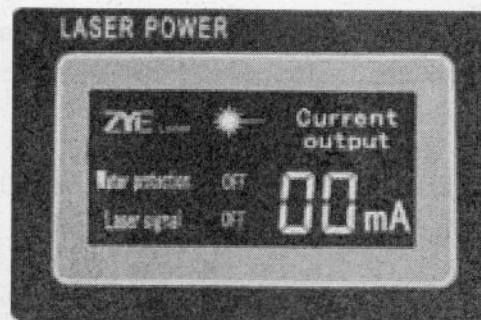
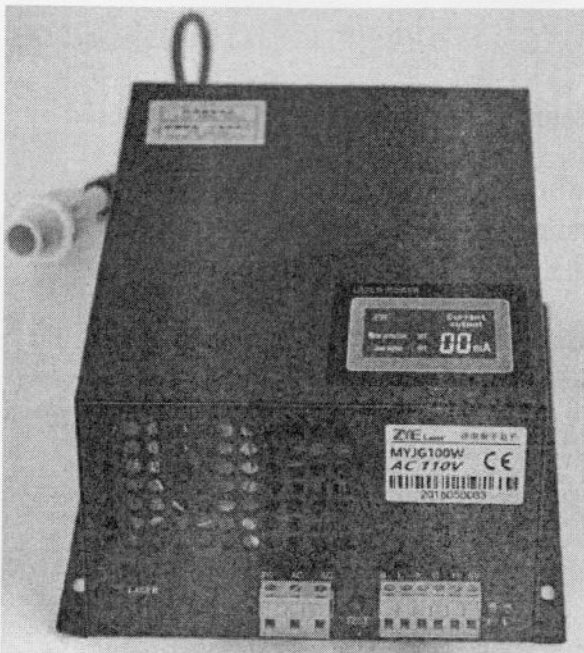

LCD Display Current and Fault Code

5.9.2 Function

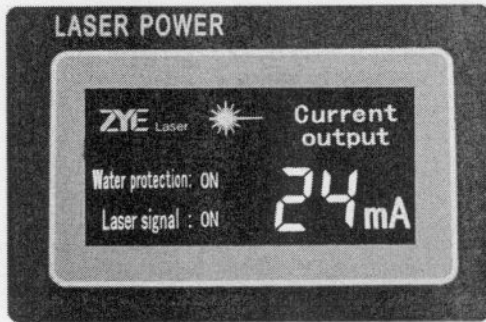

Display condition for normal working

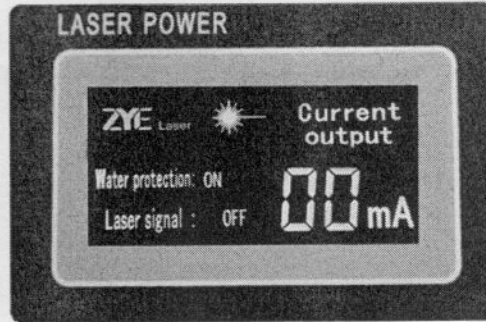

Display condition for no laser signal

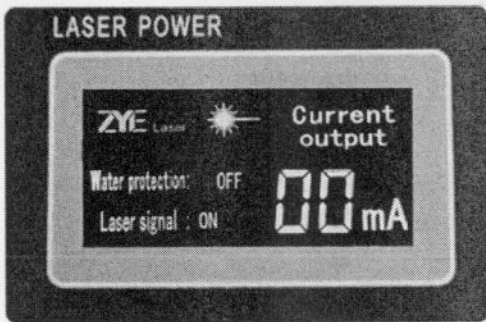

Display condition for no water protection

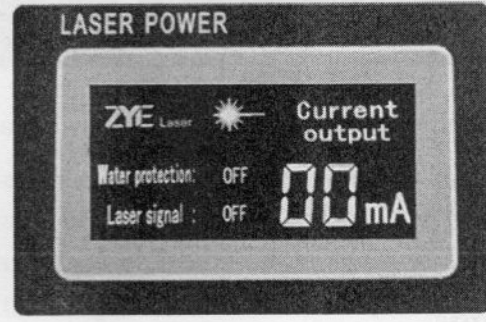

Display condition for neither water protection nor laser signal

5.9.3 Advantages

1. This series power supply has high stability feature. Because of low repair rate, it is widely used by most machine factories.
2. The high-end LCD makes display function integrate into power supply. Besides beautiful appearance, it also displays current and judges fault automatically.
3. External connected LCD module reduces damage rate on tube and power supply when bad wiring connection with ammeter. It also reduces cumbersome wiring during machine production and improves productive efficiency.
4. All mounting holes of 50W,60W,80W, 100W or 150W power supplies are the same, which is good for assembly line mount.

5.9.4 Connection of Laser Power Supply

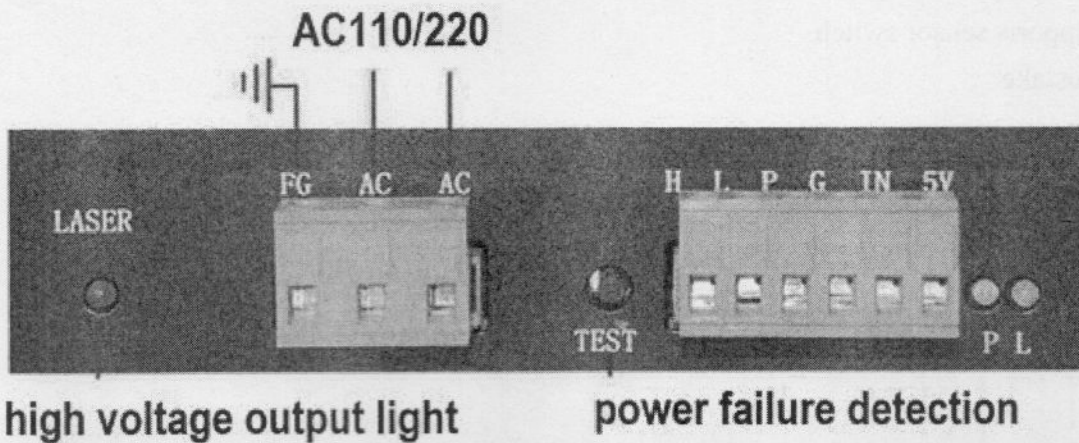

AC: Input Voltage AC220V or AC110V

H: Laser output control (When high level, it is effective)

L: Laser output control (When low level, it is effective)

P: Water protection switch (When ground connected, it is effective)

G: Signal ground

IN: Laser control signal (0~5V)

5V: 5V/50mA signal output



Water protection indicator light



Laser signal input indicator light

Troubleshooting

Here are the solutions:

Step 1. Wrong pulse setting

Reset the pulse equivalent, and for how to reset, please refer to the lesson “why cutting size doesn't match design size”

Step 2. Limit switch type mismatches laser controller.

Our controller supports sensor switch.

Step 3. Wiring mistake

Please refer to the following diagram for how to wire the limit switch.

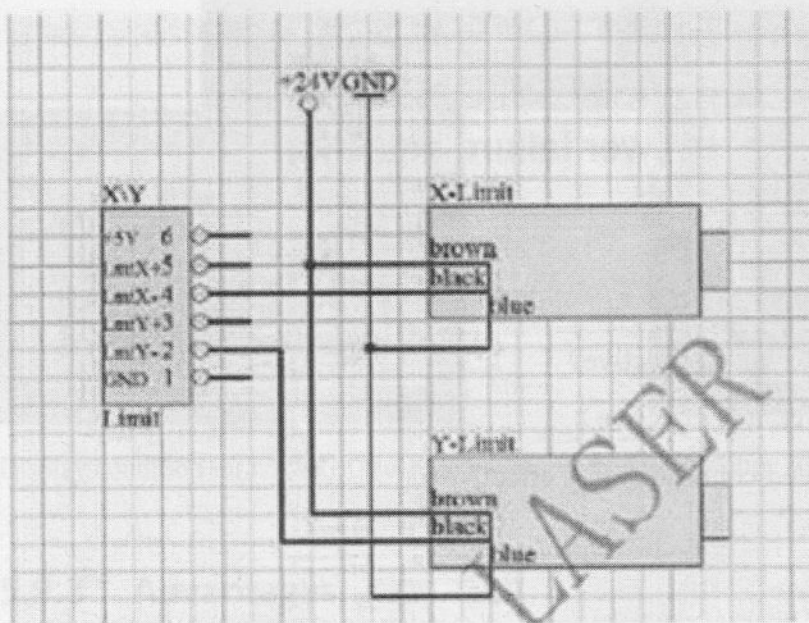

Contact Us

Thank you for your purchase. If you have any questions, please don't hesitate to contact us. We'll try our best to solve your issues ASAP.

Should you have any concern, please contact us by emailing help@cs-supportpro.com.

Thank you for using our products.